

# TAKEX PHOTOELECTRIC BEAM SENSOR

PB- 50HF-KH  
PB-100HF-KH  
PB-200HF-KH

## Instruction Manual

This product is a photoelectric beam sensor designed to be installed in a beam tower (sold separately).

**Please Note :** This sensor is designed to detect intrusion and to initiate an alarm ; it is not a burglary or a crime preventing device. TAKEX is not responsible for damage, injury or losses caused by accident, theft, Acts of God (including inductive surge by lightning), abuse, misuse, abnormal usage, faulty installation or improper maintenance.

### PRODUCT DESCRIPTION

The TAKEX intelligent "QUAD" photoelectric beam is especially designed for outdoor protection. Unique Quad beams are synchronized to work together to reinforce the range and stability in severe weather conditions. The PB-HF-KH series beams are equipped with many features which provide a wide choice of field selectable options. These options result in considerable flexibility for a variety of application requirements.

- 4 synchronized high power infrared [patented].
- Four frequencies selections.
- Beam transmission strength selection.
- Easy beam alignment.
- Auto-gain lock.
- Environmental module built-in.

## 1 PARTS DESCRIPTION

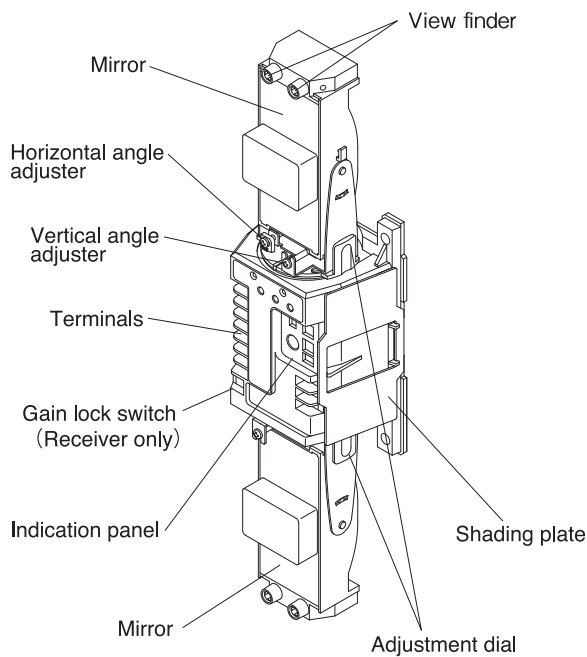

### Accessories

- Panhead screw (M3 × 12) 8

- Lock spacer 1

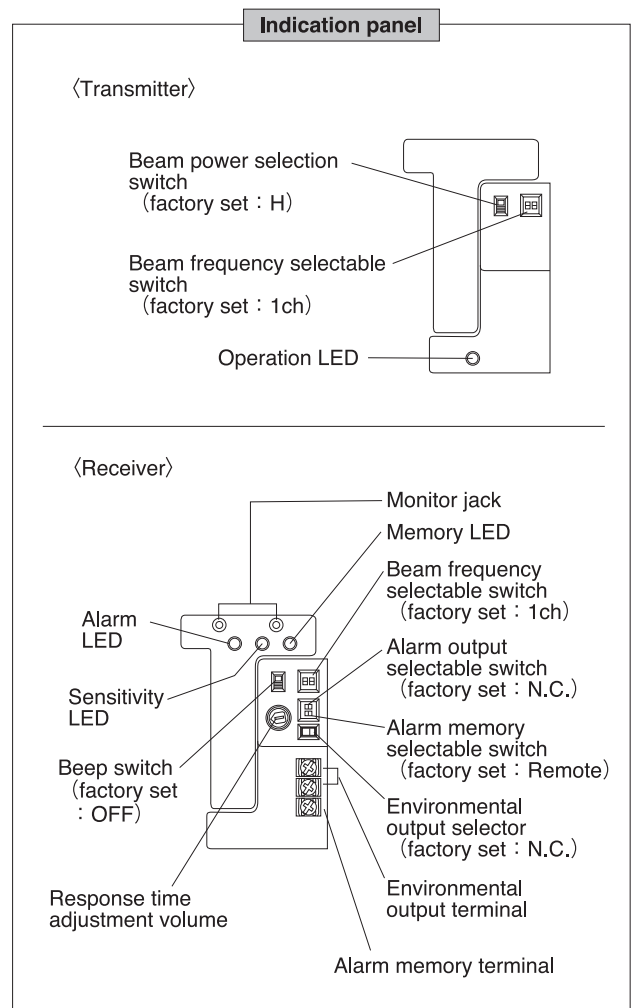

# 2 CAUTIONS ON INSTALLATION

## 1) DO'S AND DON'T'S



● Do not install the unit at places where it may be interrupted by obstacles such as trees.

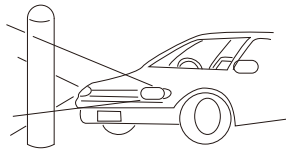

● Avoid strong light from the sun, automobile headlights etc. shining on transmitter and receiver directly. (Avoid light within  $\pm 2^\circ$  degrees of optical axis.)

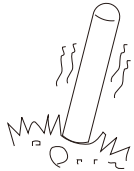

● Do not install the unit on unsteady surfaces.

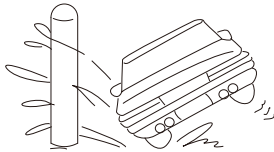

● Do not install the unit on places where it may be splashed by dirty water or direct ocean spray.

## 2) Protection distance

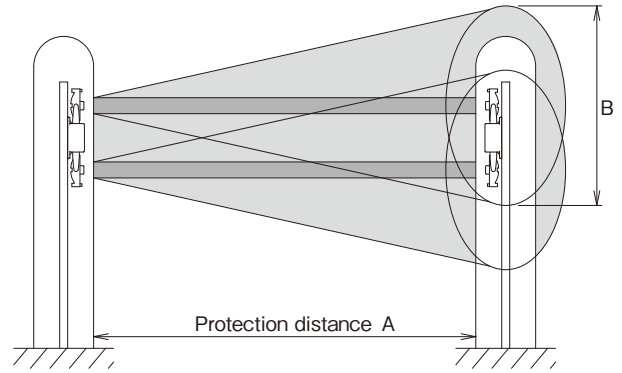

Model	A	B
PB- 50HF-KH	Up to 50m	1.2m (A=50m)
PB-100HF-KH	Up to 100m	2.4m (A=100m)
PB-200HF-KH	Up to 200m	5.0m (A=200m)

### Wiring

The equipment must be powered from an LPS in accordance with EN60950-1 : 2001

### 1) Basic connection

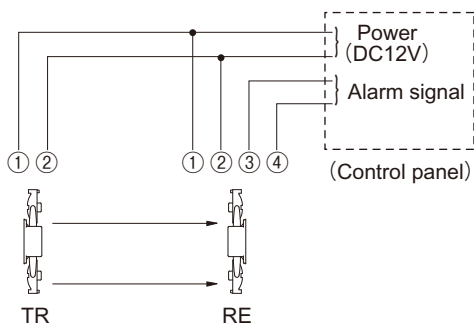

### 2) When two or more sensors are connected to the same line.

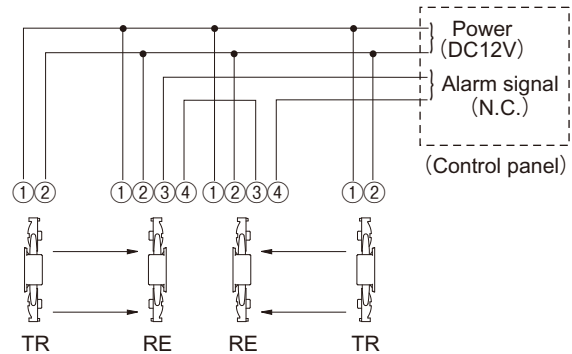

### 3) When two or more sensors are connected to separate lines.

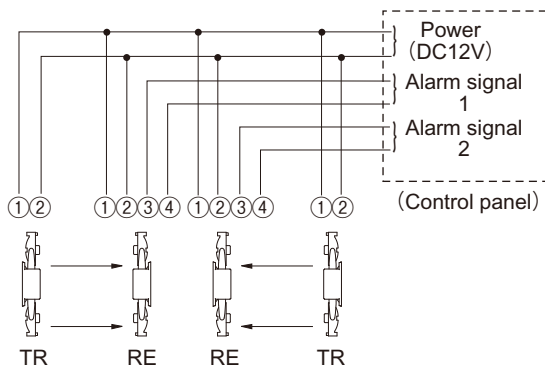

### 4) When two sensors are stacked and connected to the same line.

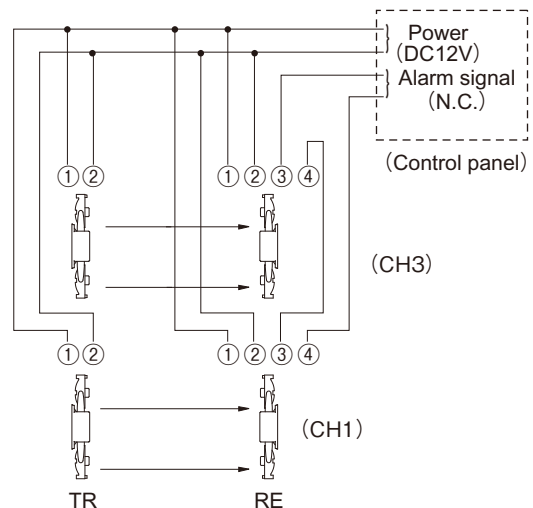

**5) When environmental output and remote alarm memory are used.**

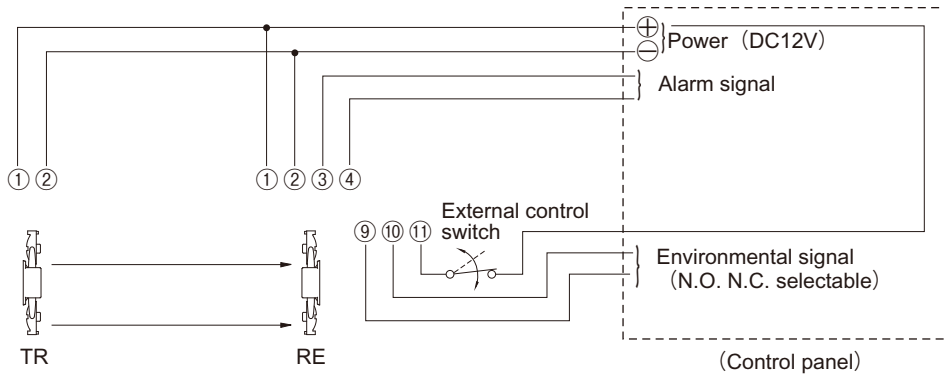

**6) Wiring distance**

Model Power voltage wire size	PB-50HF-KH		PB-100HF-KH		PB-200HF-KH	
	12V DC	24V DC	12V DC	24V DC	12V DC	24V DC
AWG20 (Dia.0.8mm)	800' (244m)	5600' (1710m)	660' (200m)	5100' (1550m)	630' (192m)	4400' (1340m)
AWG18 (Dia.1.0mm)	1250' (381m)	8800' (2680m)	1100' (335m)	7900' (2410m)	1000' (300m)	6900' (2100m)
AWG17 (Dia.1.1mm)	1500' (457m)	10500' (3200m)	1350' (400m)	9600' (2930m)	1200' (366m)	8400' (2560m)
AWG16 (Dia.1.25mm)	1950' (595m)	13500' (4000m)	1750' (534m)	12000' (3660m)	1550' (473m)	10500' (3200m)
AWG15 (Dia.1.4mm)	2500' (750m)	17000' (5180m)	2200' (670m)	15500' (4730m)	1950' (595m)	13500' (4000m)
AWG14 (Dia.1.6mm)	3200' (976m)	22500' (6860m)	2900' (884m)	20000' (6000m)	2550' (777m)	17500' (5340m)

- Note : 1) Max. wiring distance when two or more sets are connected is the above value divided by the number of sets.  
 2) The signal line can be wired to a distance of up to 6,600ft. (2,000m) with AWG 20 (dia.0.8mm) telephone wire.

**Terminal arrangement**

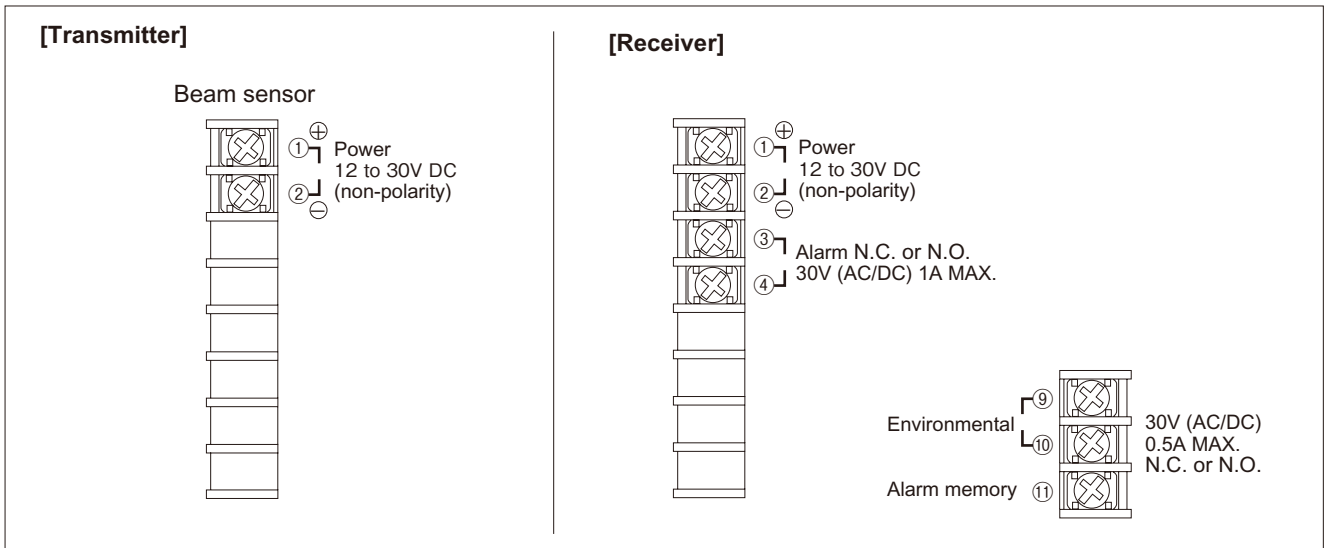

**Mounting**

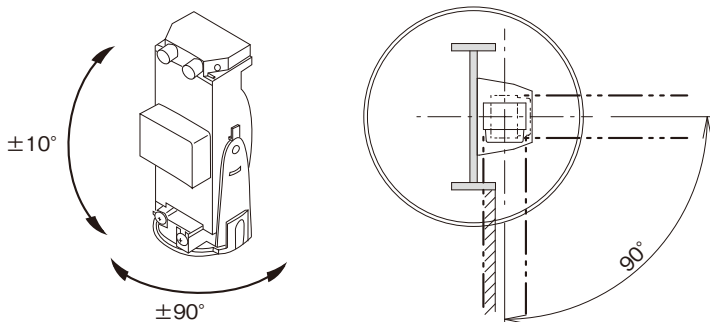

- Install the unit to a beam tower.  
Some towers could block the beam within its case when the mirror is turned by  $\pm 90^\circ$  vertically.  
Please refer to the instruction manual of the beam tower carefully before use.
- Beam sensor's reflecting mirror can be moved horizontally ( $\pm 90$  degrees) and vertically ( $\pm 10$  degrees) allowing the unit to work in all directions.

# 3 SET-UP OF FUNCTIONS AND BEAM ALIGNMENT

- 1) Supply power with covers off.
- 2) Set function options according to the right table.
- 3) Adjust optical angle.

## ●Function options

Location	Functions	Function switches
Transmitter and receiver	Beam frequency	<input type="checkbox"/> 1CH <input type="checkbox"/> 2CH <input type="checkbox"/> 3CH <input type="checkbox"/> 4CH
Transmitter only	Beam power	<input type="checkbox"/> H <input type="checkbox"/> L
Receiver only	Environmental output	<input type="checkbox"/> N.O. <input type="checkbox"/> N.C.
	Response time	<input type="checkbox"/> 0.05sec. <input type="checkbox"/> 0.3sec. <input type="checkbox"/> 0.7sec. <input type="checkbox"/> Others
	Beep switch	<input type="checkbox"/> ON <input type="checkbox"/> OFF
	Alarm output	<input type="checkbox"/> N.O. <input type="checkbox"/> N.C.
	Alarm memory	<input type="checkbox"/> Timer <input type="checkbox"/> Remote

## ●Procedure detail

- ① Look through view finder on either side upper transmitter optical unit and move until receiver unit is visible.
- ② Repeat the procedure for lower optical unit and then repeat on receiver.

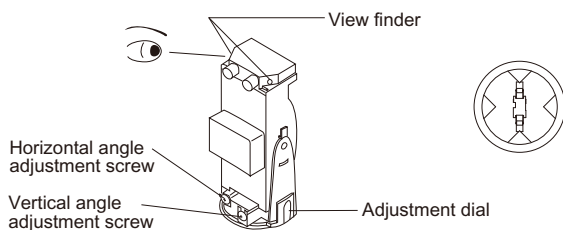

- ③ Attach the shading plates to the lower optics of both transmitter and receiver.
- ④ Turn the receiver beep switch "ON".
- ⑤ Adjust the optics with the adjustment screws until highest tone is reached.  
(Note : There will be no sound if the sensitivity LED is lit.)
- ⑥ Check output voltage by monitor output.  
A precise alignment can be accomplished by using a digital volt meter.

Voltage reading	Sensitivity
2.7V or more	Best
2.0V to 2.7V	Good
2.0V or less	Poor, re-adjust

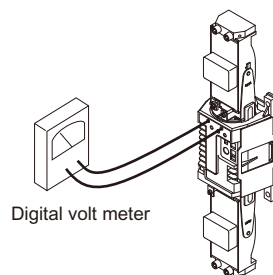

- ⑦ Reverse the procedure, i.e. attach shading plates to upper optics of transmitter and receiver and repeat adjustment.

- ⑧ After adjustment, replace the shading plates in the storage areas of transmitter and receiver.

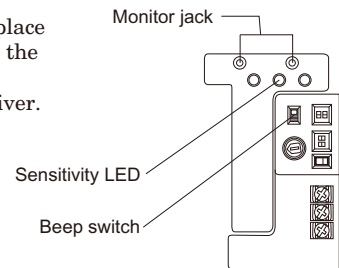

- ⑨ After beam alignment, place the covers on the beam line. Then insert a lock spacer to the micro switch part for gain lock on the receiver unit.
- ⑩ 5sec. after, sensitivity margin will be automatically set and gain lock will be completed after beep sound is heard once.  
If the beep sound is heard in an intermittent way, sensitivity is not good.  
In this case, remove the lock spacer and adjust beam alignment again.  
(Please refer to 5.5 Auto-gain lock function.)

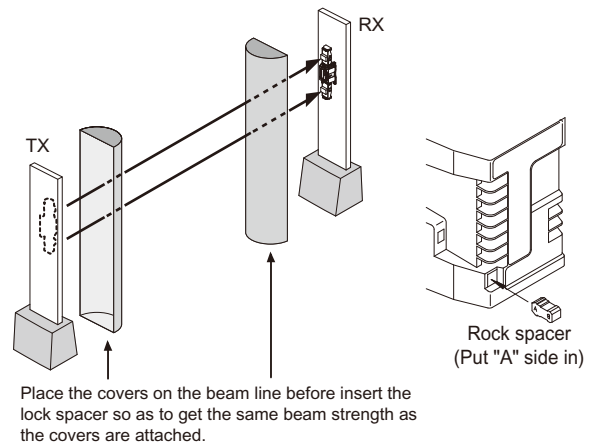

# 4 OPERATION CHECK

After installation and beam alignment, check operation by walk test. Two methods may be used.

- 1) Alarm LED only.
- 2) Alarm LED and beep tone. (Walk test mode)  
Set the beep switch to "ON", then a beep tone will be issued upon beam blockage for five minutes after the Auto gain is locked.

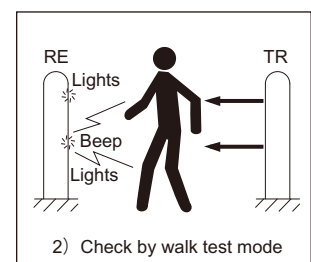
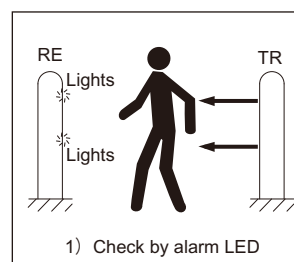

# 5 FUNCTIONS DESCRIPTION

## 1. Alarm memory function (Receiver)

The alarm memory LED indicates which sensor has triggered when two or more sensors are placed on a zone. An audible tone in addition is optional. Reset can be timer or remote.

### 1) Auto-reset

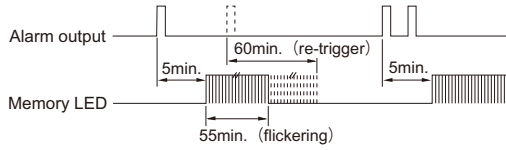

Connect terminal ① and ⊕ terminal (① or ②)

Note : If alarm memory function is not used, set the memory selector to "Remote" and leave receiver terminal ① unconnected.

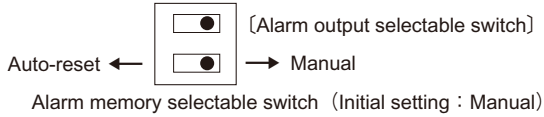

### 2) Manual

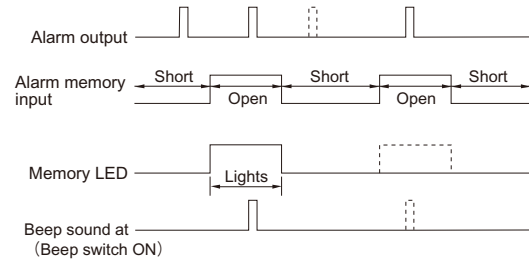

Connect / disconnect terminal ① and ⊕ terminal (① or ②)

## 2. Alarm output

N.C. or N.O. signal output is selectable.

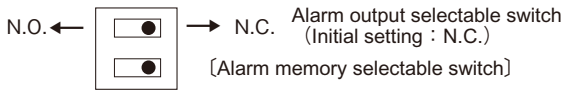

## 3. Beam power selection (Transmitter)

	L	H
PB- 50HF-KH	Up to 83' (25m)	Above 83' (25m) Up to 165' (50m)
PB-100HF-KH	Up to 248' (75m)	Above 248' (75m) Up to 330' (100m)
PB-200HF-KH	Up to 495' (150m)	Above 495' (150m) Up to 660' (200m)

## 4. Four channel frequency selection

The combination of 1CH and 3CH or 2CH and 4CH (do not use adjacent channels) are recommended to avoid crosstalk between units which are stacked, in-line, or other configurations which have the potential of spillover transmission from one beam to another. Set the frequency level as illustrated.

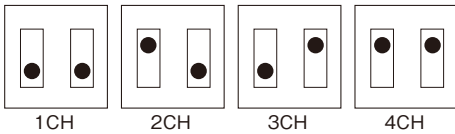

- Note : 1) Make sure both transmitter and receiver of pair are set to the same channel.  
 2) The use of voltmeter for alignment is recommended to ensure highest level of stability.  
 For stacked protection, make sure that beam sensors to be installed are the same model with the same beam power selection.  
 3) Consult with TAKEX distributor or TAKEX regional office about the frequency selection for installations not mentioned in this instruction manual.  
 Inappropriate choice of frequency may cause malfunction.

### 1) Line protection

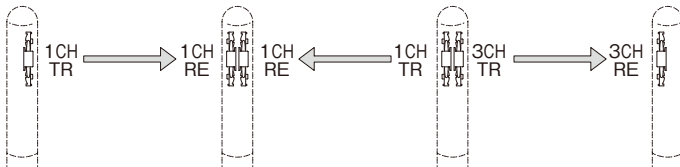

### 2) 2-stacked protection

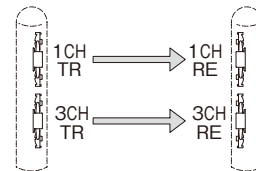

### 3) Line and 2-stacked protection

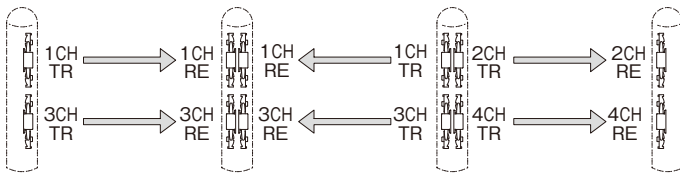

### 4) Perimeter protection

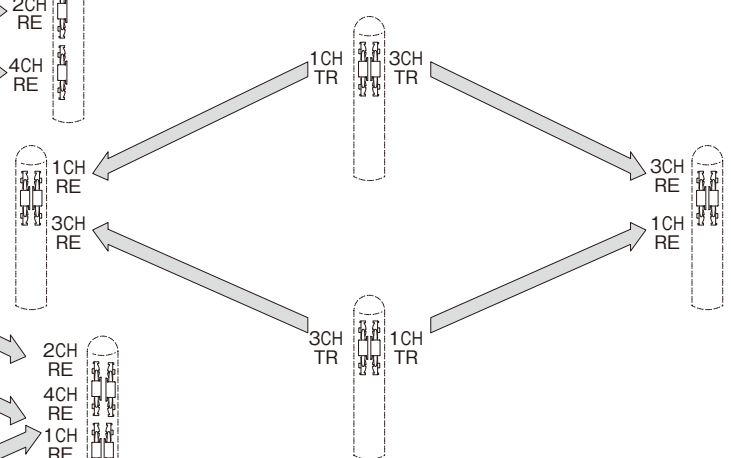

### 5) Perimeter double stacked protection

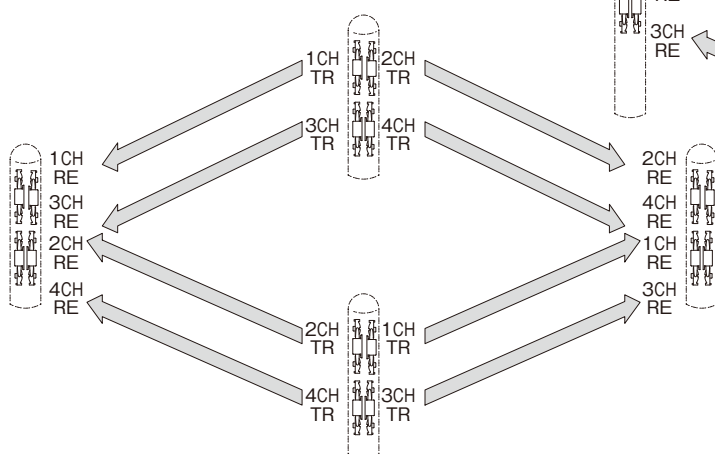

## 5. Auto-gain lock function

1) The auto-gain lock serves to standardize the responsiveness and tolerance level of the units regardless of varying distance in an installation.

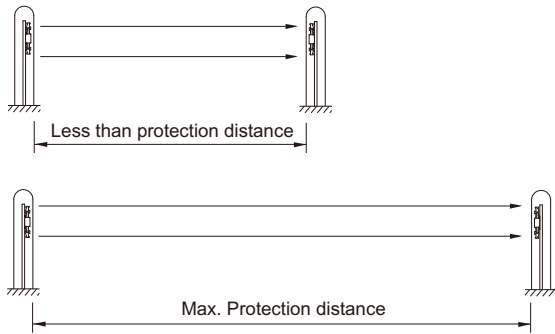

2) A "beep" tone is issued from the receiver approximately five seconds after the lock spacer is put into position. This tone indicates the Auto-gain has been set. Refer to the chart below.

Tone	Indicates	Result	Cause	Remedy
One pulse (beep)	Optimal sensitivity has been set.	OK	_____	_____
Continuous tone (20 seconds)	Optimal sensitivity cannot be set.	not good	1. Beam is interrupted once cover is replaced. 2. Beam is misaligned and sensitivity attenuation LED lights.	1. Remove obstructions and replace cover. Check beep tone. 2. Check beam power setting at transmitter with cover off and re-adjust beam alignment.

Note : 1) A tone is generated regardless of whether "beep" (alignment tone) switch is set to ON or OFF.

2) The auto-gain setting is locked in even if power is disrupted.

3) If the lock spacer is detached while power is supplied or if power is discontinued, the auto-gain automatically resets to maximum sensitivity.

## 6. Tone indicator

Test / Signal	Alignment tone switch	Other condition	Description
Beam alignment	ON	Lock spacer detached	Reception strength monitored. Tone pitch increases as reception improves. Note : No tone is given if sensitivity attenuation LED is lit or if the lock spacer is attached.
Auto-gain lock	_____	About 5sec. after the lock spacer is attached.	Short tone indicates lock is set. Continuous tone (20sec.) indicates readjustment.
Walk test	ON	For approx. 5min. after gain is locked.	Tone is linked to alarm LED. Both trip simultaneously.
Alarm memory	ON	Set to manual memory	"Beep" is indicated if alarm condition occurs.

## 7. Response time

Adjust response time as follows. The unit does not detect the passing object faster than the response time set.

If the response time is set extremely long, the unit may be unable to detect human pattern. Adjust a little longer response time in a site where large passing objects such as birds, newspapers or falling leaves may move.

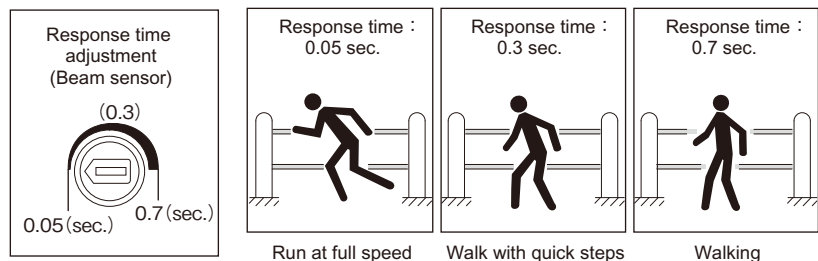

## 8. Environmental check

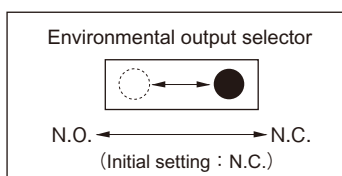

The environmental signal is initiated if the beam reception level is reduced by poor weather conditions (dense fog or torrential rain etc.).

N.C. or N.O. signal output is selectable.  
(Contact capacity 30V (AC/DC) 1A MAX.)

# 6 TROUBLESHOOTING

Symptom	Possible cause	Remedy
Transmitter LED does not light	1. No power supply	1. Turn on the power
	2. Bad wiring connection, or broken wire, short	2. Check wire
Receiver LED does not light when the beam is broken	1. No power supply	1. Turn on the power
	2. Bad wiring connection	2. Check wire
	3. Photoelectric beam is reflected on another object and sent into the receiver	3. Remove the reflecting object or change the place for installation
	4. 4 photoelectric beams are not broken simultaneously	4. Interrupt 4 beams simultaneously
Receiver LED continues to light (An alarm does not stop)	1. Alignment is off	1. Check and adjust again
	2. Shading object between transmitter and receiver	2. Remove the shading object
	3. Optics of units are soiled	3. Clean the optics with a soft cloth
	4. Frequency channel setting on transmitter does not match with that on receiver	4. Readjust to be the same channel
Intermittent alarm	1. Bad wiring connection	1. Check again
	2. Change of supply voltage	2. Stabilize supply voltage
	3. Shading object between transmitter and receiver	3. Remove the shading object
	4. A large electric noise source such as power machine, is located nearby transmitter and receiver	4. Change the place for installation
	5. Unstable installation of unit	5. Stabilize
	6. Optics of units are soiled	6. Clean the optics with soft cloth
	7. Improper alignment	7. Check and re-adjust
	8. Small animals may pass through the 4 photoelectric beams	8. Change installation site or environments
	9. Installation site or installation height is not appropriate	9. Re-adjust the installation site or height

# 7 SPECIFICATIONS

Type	Photo electric beam sensor		
Model	PB-50HF-KH	PB-100HF-KH	PB-200HF-KH
Protection distance	165ft. (50m) or less	330ft. (100m) or less	660ft. (200m) or less
Max. arrival distance	1650ft. (500m) (tenfold margin distance)	3300ft. (1000m) (tenfold margin distance)	6600ft. (2000m) (tenfold margin distance)
Infrared beam	LED (pulsed beam by LED) Double modulation		
Detection system	Photoelectric beam		
Response time	0.05sec. to 0.7sec. (Variable at pot)		
Alarm signal	Dry contact relay output N.O. / N.C. Contact action : Interruption time + delay time (approx. 2sec.) Contact capacity : 30V (AC/DC) 1A		
Environmental signal	Dry contact relay output N.O. / N.C. Contact capacity : 30V (AC/DC) 0.5A		
Supply voltage	12 to 30V DC		
Power consumption	When alarmed 60mA or less ● Transmitter : 15mA or less ● Receiver : 45mA or less When adjusted 95mA or less	When alarmed 70mA or less ● Transmitter : 25mA or less ● Receiver : 45mA or less When adjusted 105mA or less	When alarmed 85mA or less ● Transmitter : 40mA or less ● Receiver : 45mA or less When adjusted 120mA or less
Functions	Alignment tone switch, Attenuation LED, Monitor jack, Alarm memory indication, Modulation frequency selectable (4stage), Environmental check, Automatic gain control (AGC) circuit,		
Weight	Transmitter 10.6oz (300g) Receiver 14.1oz (400g)		
Appearance	ABS resin		

# 8 EXTERNAL DIMENSIONS

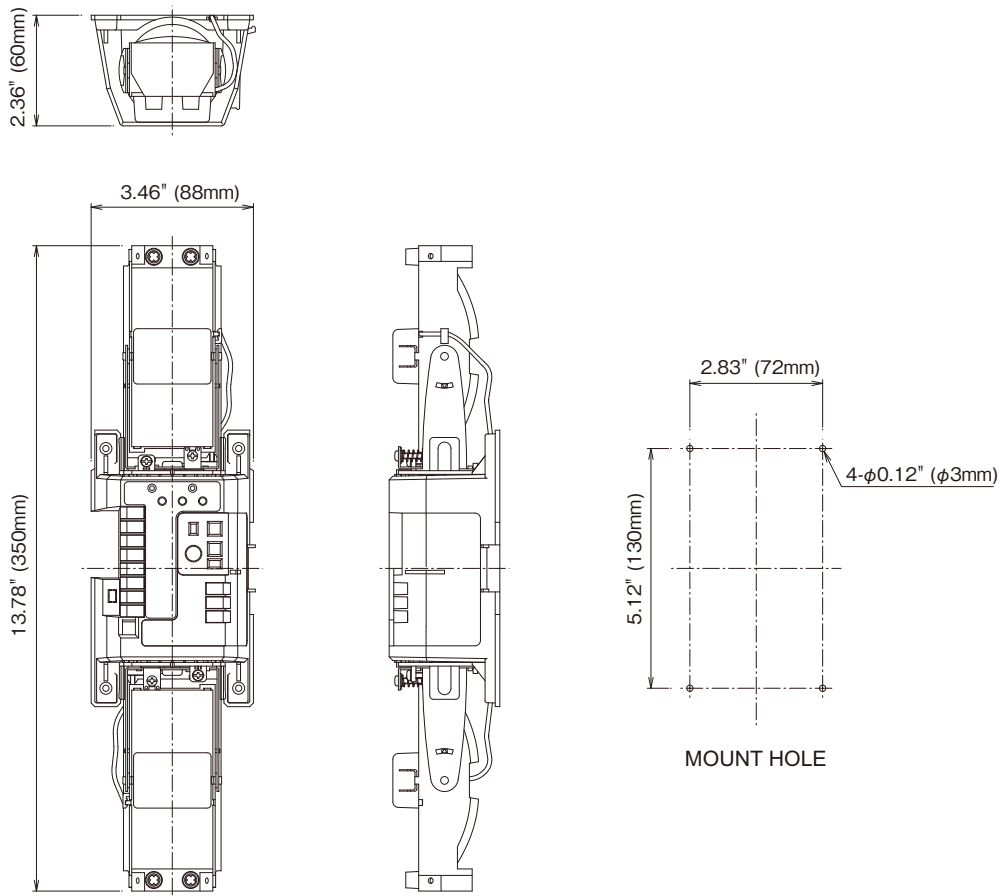

# 9 SPECIAL NOTES

This equipment has been tested and found to comply with the limits for a Class B digital device, pursuant to part 15 of the FCC Rules. These limits are designed to provide reasonable protection against harmful interference in a residential installation. This equipment generates, uses and can radiate radio frequency energy and, if not installed and used in accordance with the instructions, may cause harmful interference to radio communications. However, there is no guarantee that interference will not occur in a particular installation. If this equipment does cause harmful interference to radio or television reception, which can be determined by turning the equipment off and on, the user is encouraged to try to correct the interference by one or more of the following measures :  
 —Reorient or relocate the receiving antenna. —Increase the separation between the equipment and receiver. —Connect the equipment into an outlet on a circuit different from that to which the receiver is connected. —Consult the dealer or an experienced radio / TV technician for help.

**WARNING :** Changes or modifications not expressly approved by the party responsible for compliance could void the user's authority to operate the equipment.

### Limited Warranty :

TAKEX products are warranted to be free from defects in material and workmanship for 12 months from original date of shipment. Our warranty does not cover damage or failure caused by Acts of God (including inductive surge by lightning), abuse, misuse, abnormal usage, faulty installation, improper maintenance or any repairs other than those provided by TAKEX. All implied warranties with respect to TAKEX, including implied warranties for merchantability and implied warranties for fitness, are limited in duration to 12 months from original date of shipment. During the Warranty Period, TAKEX will repair or replace, at its sole option, free of charge, any defective parts returned prepaid. Please provide the model number of the products, original date of shipment and nature of difficulty being experienced. There will be charges rendered for product repairs made after our Warranty period has expired.

## TAKENAKA ENGINEERING CO., LTD.

In Japan

**Takenaka Engineering Co., Ltd.**  
 83-1, Gojo-sotokan, Higashino,  
 Yamashina-ku, Kyoto 607-8156, Japan  
 Tel : 81-75-501-6651  
 Fax : 81-75-593-3816  
<http://www.take-ex-eng.co.jp/>

In the U.S.

**Takex America Inc.**  
 230E, Caribbean Drive  
 Sunnyvale, CA 94086, U.S.A.  
 Tel : 408-747-0100  
 Fax : 408-734-1100  
<http://www.take-ex.com>

In Australia

**Takex America Inc.**  
 Unit 16/35 Garden Road, Clayton,  
 3168 Victoria, Australia  
 Tel : 03-9546-0533  
 Fax : 03-9547-9450

In the U.K.

**Takex Europe Ltd.**  
 Takex House, Aviary Court, Wade Road,  
 Basingstoke, Hampshire. RG24 8PE, U.K.  
 Tel : (+44) 01256-475555  
 Fax : (+44) 01256-466268  
<http://www.take-ex-europe.com>