



VAPE SENSOR

VS-1000E

FUNCTIONS

- Detects vaping and smoking in restrooms and similar areas
- Adjustable detection sensitivity (Standard/Low)
- Selectable alarm contact output (N.C./N.O.)
- Enable/disable LED indicator
- Dedicated terminal for interconnecting multiple units
- Quick-to-install screwless terminals
- Tamper-resistant cover locking mechanism
- Suitable for ceiling or wall mounting



Designed to combat the growing problem of teenage vaping on school grounds and other similar environments

HIGH SENSITIVITY PARTICLE SENSOR

VS-1000E detects vaping and smoking by airborne particles.

VERSATILE USE

The dry contact relay (N.C./N.O. selectable) simplifies connection to existing alarm systems.

INTEGRATED ALARM BUZZER

The built-in buzzer provides immediate local notification of detected vaping or smoking.

DISCREET DESIGN

The unobtrusive design blends seamlessly into any environment.

FALSE ALARM IMMUNITY

Advanced detection algorithms adapt to changes in the surrounding environment, significantly reducing the occurrence of false alarms.

CONFIGURABLE ALARM OUTPUT

Choose between one shot (approx. 2sec.) or Real-time output modes depending on your specific application needs.

SELF-DIAGNOSIS

The sensor automatically monitors its own operation and triggers an alarm output and LED indication in the case of voltage abnormality or module failure.

VAPE SENSOR

■ INSTALLATION

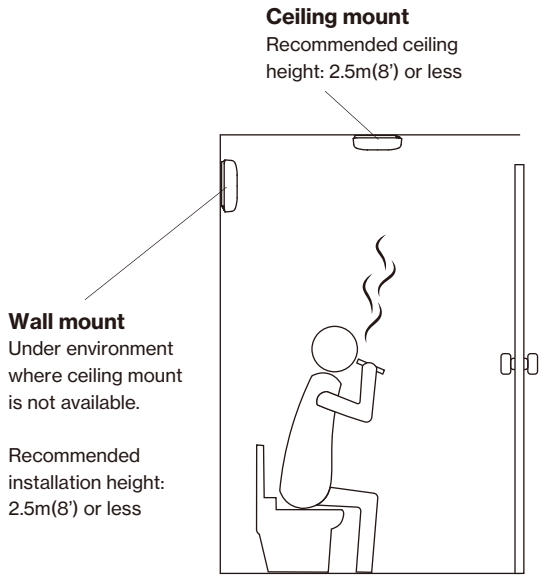

■ EXTERNAL DIMENSIONS

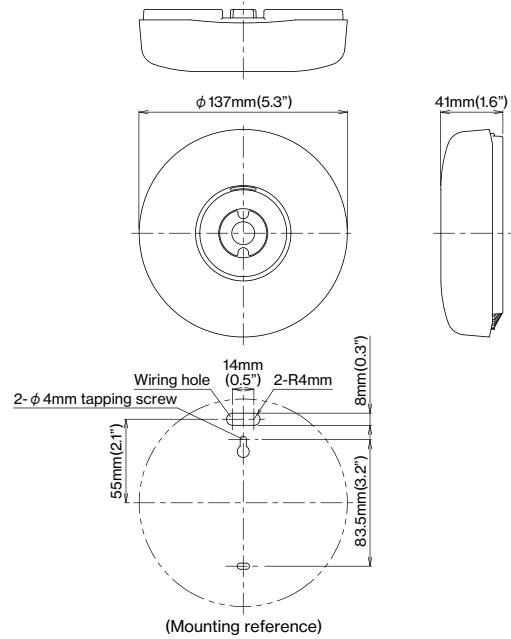

■ CONNECTION

[2 sensors connected]

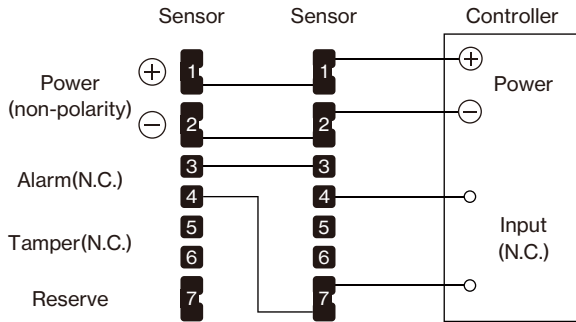

■ WIRING DISTANCE

Wire size \ Voltage	12V DC	24V DC
AWG 22 (Dia.0.65mm)	50m(165')	700m(2,300')
AWG 20 (Dia.0.8mm)	100m(330')	1,100m(3,600')
AWG 18 (Dia.1.0mm)	200m(660')	1,800m(5,900')
AWG 16 (Dia.1.25mm)	300m(1,000')	3,000m(10,000')

*When 2 or more units are connected, the wiring distance is calculated as follows : [Above / number of units]

■ SPECIFICATIONS

Product name	VAPE SENSOR
Model	VS-1000E
Supply voltage	10.5V to 28V DC (non-polarity)
Current consumption	85mA max.
Alarm output	Contact : Solid state relay (N.C./N.O. selectable) Operation : One shot (approx. 2sec.) / Detecting time Capacity : 30V (AC/DC) 0.2A (resistive load)
Tamper output	Contact : Dry contact relay (N.C.) Operation : Activated when cover is detached (Continuous output) Capacity : 30V (AC/DC) 0.1A (resistive load)
Alarm LED (Red)	Warm-up : Blinking Detection : Lights on (LED ON/OFF selectable) Error : Fast blinking
Buzzer	Sound at detecting (disable / 10sec. / 30sec. / continuous)
Wiring connection	Screwless terminal
Ambient temperature	0°C to +50°C (+32°F to +122°F) without condensation / frozen
Mounting position	Indoor (Ceiling / Wall)
Weight	210g (7.4oz)
Appearance	Resin (Body: White / Base: Black)

*Specifications and design are subject to change without prior notice.

*This product is **NOT** Fire Alarm equipment such as Fire/Smoke detectors.

Limited Warranty :

TAKEX products are warranted to be free from defects in material and workmanship for 12 months from original date of shipment. Our warranty does not cover damage or failure caused by Acts of God (including inductive surge by lightning), abuse, misuse, abnormal usage, faulty installation, improper maintenance or any repairs other than those provided by TAKEX. All implied warranties with respect to TAKEX, including implied warranties for merchantability and implied warranties for fitness, are limited in duration to 12 months from original date of shipment. During the Warranty Period, TAKEX will repair or replace, at its sole option, free of charge, any defective parts returned prepaid. Please provide the model number of the products, original date of shipment and nature of difficulty being experienced. There will be charges rendered for product repairs made after our Warranty period has expired.



In Japan

Takenaka Engineering Co., Ltd.
83-1, Gojo-Dori, Sotokan Nishi-iru, Higashino, Yamashina-ku, Kyoto 607-8156, Japan
Tel : 81-75-501-6651

<https://www.takex-eng.co.jp/>

In the U.S.

Takex America Inc.
1810 Oakland Rd, Suite F, San Jose, CA 95131, USA
Tel : 408-747-0100

<https://www.takex.com>

In Australia

Takex America Inc.
4/15 Howleys Road, Notting Hill, VIC, 3168
Tel : +61 (03) 9544-2477

<https://www.takex.com>

In the U.K.

Takex Europe Ltd.
Aviary Court, Wade Road, Basingstoke, Hampshire. RG24 8PE, U.K.
Tel : (+44) 01256-475555

<https://www.takex.com>