

TAKEX

FLAME SENSOR

FS-1000E

Instruction Manual

We appreciate your purchase of TAKEX flame sensor.
Please read this instruction manual carefully for correct and effective use.

This sensor is designed to detect flames and to initiate an alarm, it is not a fire-preventing device.
TAKEX is not responsible for damage, injury or losses caused by accident, theft, Acts of God (Including inductive surge by lightning), abuse, misuse, abnormal usage, faulty installation or improper maintenance.



This sensor detects Ultraviolet rays in the flames and initiates an alarm.
It does not detect smoke, heat.

PRODUCT DESCRIPTION

Flame sensor FS-1000E is designed to detect ultraviolet rays contained in flames, and to initiate an alarm.
This sensor can be operated for 2years with popular type-AA alkaline battery 2 pcs.
Also, by wiring, external power supply (9V DC~30V DC) is available.
The equipped output terminal enables remote control of other warning devices, and system operation with a control panel.
Easy separation of the sensor unit and the base unit is very useful for simplifying installation and maintenance.

1 PARTS DESCRIPTION

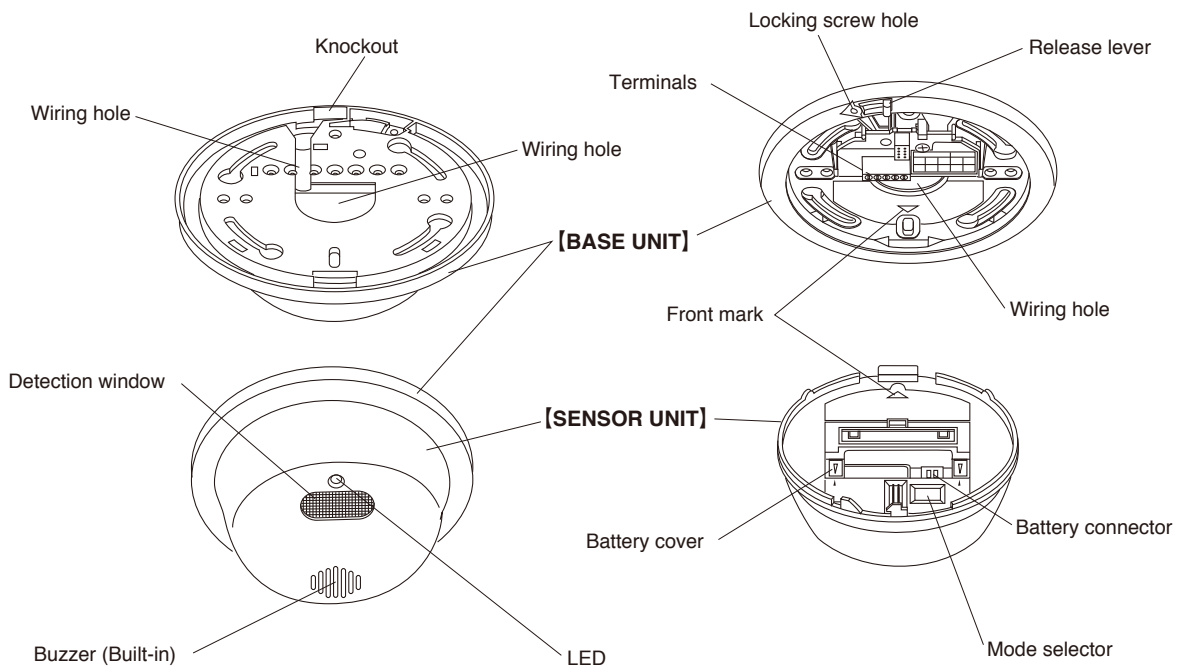

ACCESSORY

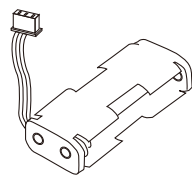

Battery case for type-AA
(1 piece)



Sensor locking screw
φ 3×6 (1 piece)



Tapping screw
φ 4×25 (2 pcs.)

*Type-AA battery is not included

2 ATTENTION

Product classification

This sensor is designed to detect ultraviolet rays contained in flames, and to issue a signal.

This unit is neither fire detector nor heat detector nor smoke detector.

TAKEX is not responsible for damage, injury or losses by fire, accident, calamity, Acts of God (including inductive surge by lightning), abuse, misuse, abnormal usage, faulty installation or improper maintenance.

Others

- When an strong impact is given to the sensor, it may cause damage, malfunction or less performance. Do not handle in a rough manner.
- Intense flames such as gas explosion's may damage the sensor, and there may be no detection.

Objects to be detected

This sensor detects ultraviolet rays contained in flames. Therefore, this sensor may detect other sources of ultraviolet rays. This sensor does not detect burning objects which are smoldering.

Possible cause of false alarm Do not install the sensor nearby the followings.	Flames which can not be detected.
<ul style="list-style-type: none"> ●Halogen lamp ●Electric discharging lamp such as mercury lamp ●Electric sterilizer lamp ●Spark from welding ●Electric spark (caused by motor, pantograph) ●Sunlight ●Lightning discharge ●High voltage electric field ●All objects which emit ultraviolet rays 	<ul style="list-style-type: none"> ●Flames through glass or transparent resin ●Lit portion of cigarette ●Burning charcoal or briquet ●Electric stove ●Smoldering object

3 DO'S AND DON'T'S

- Carefully select the installation site and set up the sensor to avoid dead spots.
- Do not install in the following places.

- Do not install in a site which is subject to direct or reflecting sunlight and rain. (This sensor is for indoor use only)

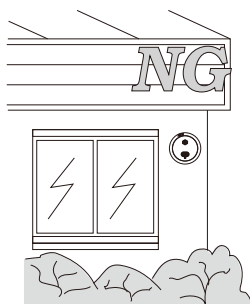

- Do not install in high humid place such as a bathroom.



- Do not install in a site where fire (flame) is usually used such as a kitchen.

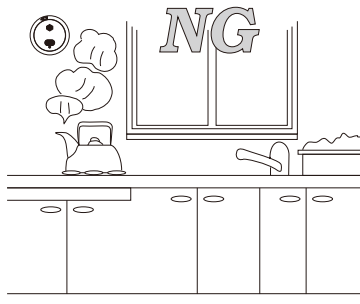

- Do not install in front of the object that intercepts light. (including glass and transparent resin etc.)

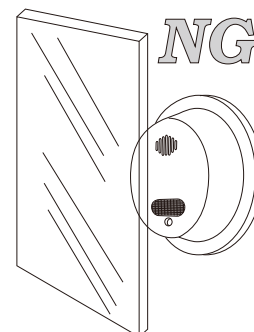

- Do not install in a site where the temperature falls to less than +14°F (-10°C) or rises more than +140°F (+60°C).
- Do not install the sensor nearby the possible cause of false alarm. (see section 2)
- Do not give an impact to the sensor. it may cause damage, malfunction and less performance to the sensor.
- Do not put water on the sensor, or leave the sensor in a humid place. it may cause malfunction.
- Only type-AA Alkaline battery (2 pcs.) can be used. Do not use manganese battery because of its short life.
- When low battery alarm is initiated, exchange the battery immediately. If not, the sensor may not work.

- This sensor's alarm action is 10 sec. offdelay action. By detecting a flame, the alarm will be initiated after the set time of timer passed. The alarm action is continued during the fire, and stopped 10 sec. later after the extinction. (Alarm, LED, external output)

4 WIRING

Wiring is not necessary if power is supplied from battery and external output is not used.

Terminal arrangement

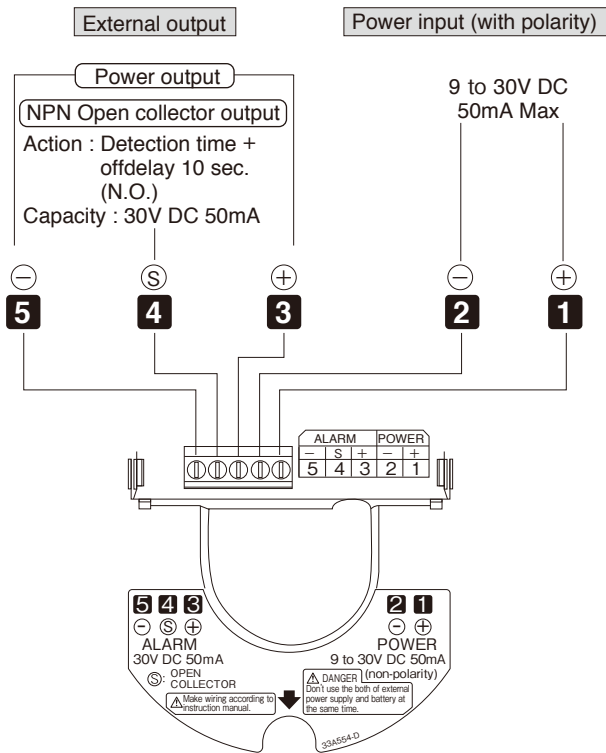

- Single wire (0.14~1.5mm²) and twisted wire (0.14~1.0mm²) can be used for the terminals.
- When power cable is wired, remove battery cover to keep wiring space.

How to use Input / Output

- ① Power input (terminal (1), (2))
 - Do not use with battery at same time.
 - Do not reverse the polarity.
- ② External output

The following either (1) or (2) output is available by connecting open collector output terminal (S) and either ⊕ or ⊖ of external output terminals.

 1. Signal output (terminal (4), (5))

N/O signal is issued for a control panel etc.

When more than 2 sensors are connected on 1 circuit, make wiring in parallel.
 2. Output with voltage (terminal (3), (4))

This output is not available with battery use at the same time. Alarm signal is switched to power input with voltage. (Output voltage is decreased by approx. 1V compared with input voltage.) Within the capacity of contact output, alarm devices (power consumption within 50mA) can be operated by this output. This is useful for remote control of warning devices etc.

• Example of basic connection

(Remote control by control panel) --- terminal (4), (5)

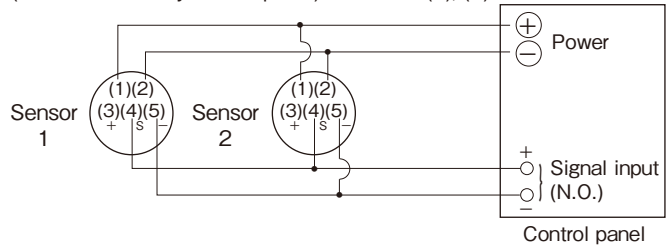

(Remote control of warning devices) --- terminal (3), (4)

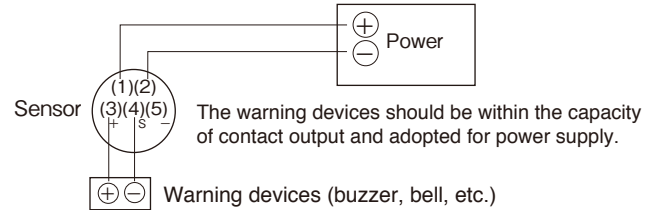

5 INSTALLATION

- ① Locate the installation site. (Ref : 3, DO'S AND DON'T'S and 7, DETECTION AREA)
- ② Slide the release lever to detach the sensor unit.

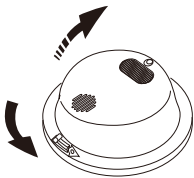

- ③ Fix the base with the screws included. (Ref : Base installation described later)

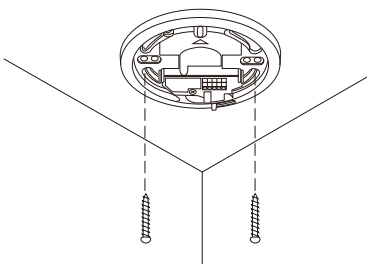

④ Power supply by battery.

- (1) Detach the battery cover from the back side of sensor unit with fingers.
- (2) Put Type-AA batteries into battery case with the correct polarity.
- (3) Plug the connector of battery case into the main body and confirm the warm-up sound.
- (4) Put wire first and the battery case next, into the main body.
- (5) Attach the battery cover so that the marks △ on the cover. Face the marks ▼ on the back of the sensor.

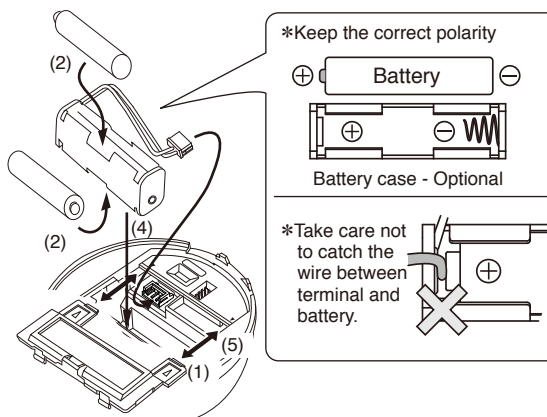

Power supply by wiring

- (1) Connect wire to terminals of the base. (Ref : 4, WIRING)
- (2) Detach the battery cover from the back side of sensor unit with fingers in order to keep the wiring space.

※ To make the exposed wiring, break the knockout and insert wires into the wire lead.

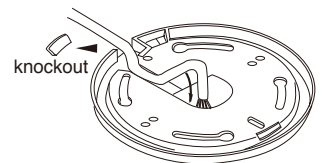

⑤ Set alarming sound, detection sensitivity and detection timer. (Ref : 6-(2) Function setting)

⑥ Attach the sensor unit to base unit.

- (1) Turn front marks of base unit and sensor unit to point in the same direction.
- (2) Insert sensor unit into base unit.
- (3) Push sensor unit until release lever is locked.

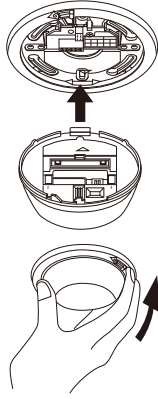

⑦ Check operation and area. (Ref : Operation check)

⑧ When sensor unit is detached, wrap it in palm and slide release lever.

⑨ To lock sensor unit, insert sensor locking screw into locking screw hole and tighten it.

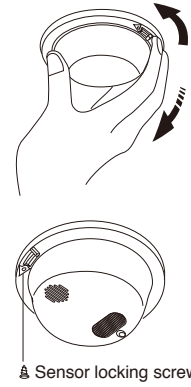

Ⓐ Sensor locking screw

[Installation of base]

● Installation hole

This product is equipped with installation holes (pitch 3.29" or 83.5mm) to make installation easy and the sensor's direction adjustable.

Installation hole

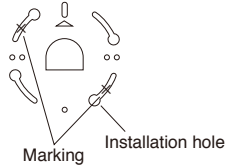

(1) Place the base on the site and mark X on 2 points 180° apart.

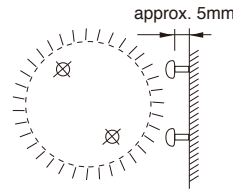

(2) Insert the 2 pcs. of tapping screws (accessory) leaving 5mm exposed from the surface.



(3) Adjust the sensor's direction by turning the base.

(4) Tighten the screws.

6 OPERATION AND FUNCTION

(1) Operation

Alarm (Basic action)

This product alarms only by detecting a flame continuing for the set time of detection timer. (1sec., 6secs., 15secs., 30secs.)

[Buzzer : Sounds intermittently every 0.2sec.]
[LED : Flashing every 0.2sec.]

When the flame continues further, the alarm and external output (when wired) are also continued 10sec. after the flame goes out, the alarm stops and the sensor goes back to armed mode.

Low battery alarm

Low battery alarm will be initiated when power is supplied from a battery.

[Buzzer : Sounds intermittently every 5sec.]
[LED : Flashing every 5sec.]

When low battery alarm sounds, change the battery for new one. (The sensor stops its operation 2 weeks after the low battery alarm starts.)

Power on notice

Power on notice will sound when the power is turned on. [Buzzer : Sounds intermittently 3 times.]

When voltage is low, power on notice will not be heard. Check the power supply (battery).

Within 30sec. after the power is turned off, power on notice is not issued even if the power is supplied again.

(2) Mode setting

FS-1000E is equipped with 3 functions which can be used according to the application or environment. Mode setting will be done by mode selector (dip switch) in accordance with mode setting chart on the back side of sensor unit.

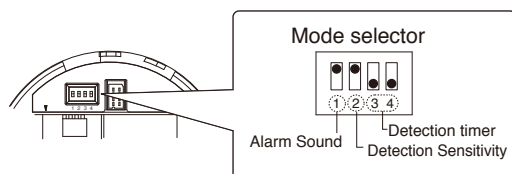

Alarm sound (buzzer)

Buzzer can be off by mode selector No.1,

※ When the setting is OFF Buzzer of "Low battery alarm" and "power on notice" are also off.

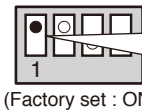

(Factory set : ON)

SET	
<input checked="" type="checkbox"/>	ON
<input type="checkbox"/>	OFF

Detection Sensitivity

Detection sensitivity is selectable, H or L.

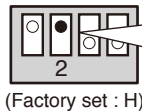

(Factory set : H)

SET		SET	
<input checked="" type="checkbox"/>	L (50%)	<input checked="" type="checkbox"/>	H (100%)

※ When detection sensitivity is set "L", the detection distance is 50% shorter than when it is set "H".

※ When operation is unstable on "H" setting, select "L".

※ For semi-outdoor installation, "L" setting is recommended.

Detection timer

An alarm output occurs when the flame continues for set time of detection timer or longer.

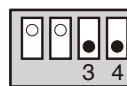

(Factory set : 1 sec.)

SET	Timer	Application and installation
<input checked="" type="checkbox"/>	1 sec.	● For the quick detection of the flame of lighter / match at no smoking zone.
<input checked="" type="checkbox"/>	6 sec.	● Fire detection
<input checked="" type="checkbox"/>	15 sec.	● In case of uncertain operation on the above
<input checked="" type="checkbox"/>	30 sec.	● Fire detection in an area that may be influenced by uncertain external light

※ When the ultraviolet rays of a flame is weak (it is related to size of flame and distance to sensor), alarm initiation may be delayed beyond the set time.

※ The ultraviolet rays are not visible, and may be detected from unexpected object.

When the sensor's operation is not stable (it detects something but not a flame) and its cause can not be identified, set detection time longer by one step and see the course.

7 DETECTION AREA

- 1) Detection area spreads out in front of the sensor at approx. 120° conically.
- 2) The size of the detection area is in proportion to the size of the flame.
The size of the detection area increases with an increase in flame size and duration.
When the object of detection is from a source such as a lighter, confirm detection throughout the area.
- 3) Use the optional BCW-401 universal bracket when area adjustment is required.

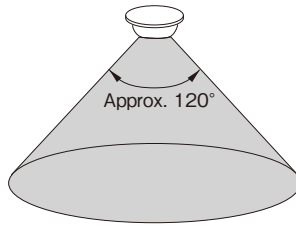

Detection area

- Factory default setting
Detection timer : 1 sec.
Detection sensitivity : H (100%)
Detection object : Gas flame of lighter [2.75" (7cm)]

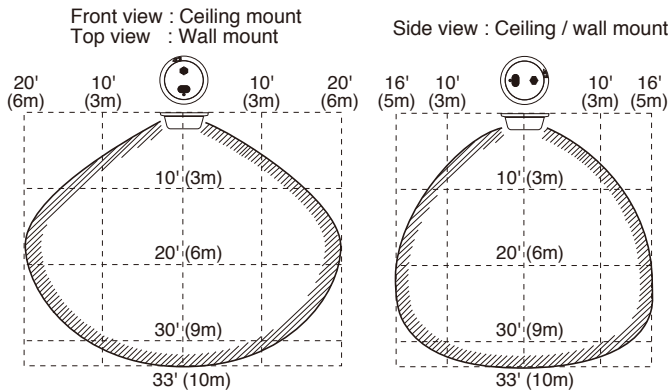

8 OPERATION CHECK

1. Turn power on, and confirm power on notice sounds.
(In case of battery use, confirm power on notice when connecting the battery.)
2. Ignite a lighter etc. within detection area for more than the set time.
3. After the set time, buzzer sounds intermittently and LED flashes. (Alarm action)
4. 10sec. after the flame goes off, the above alarm action ends.

(When external output is used by wiring, a continuous output is issued during the above 3. and 4. alarm action. Confirm the operation of the connected devices.)



Do not use a lighter in no fire zone because it is dangerous. In such case, operation test have to be done in other place with sensor only.

9 TROUBLESHOOTING

Solve possible problems according to the following table .
If normal operations can not be restored by these corrective actions, contact either the dealer from whom you bought the unit or TAKEX.

Trouble	Check	Corrective action
Completely inactive	<ul style="list-style-type: none"> ●No battery connected ●Low battery 	<ul style="list-style-type: none"> ●Connect battery ●Change battery
	<ul style="list-style-type: none"> ●No power supply (Broken wire or improper wire) ●Low voltage (When power supply wired) 	<ul style="list-style-type: none"> ●Correct power supply or replace broken wire
	<ul style="list-style-type: none"> ●Interrupting rays objects in front of detection area (Glass, transparent resin are interrupting rays objects) 	<ul style="list-style-type: none"> ●Remove the interrupting rays object
	<ul style="list-style-type: none"> ●Sensor inside is wet by condensation etc. 	<ul style="list-style-type: none"> ●Dry out sensor inside, and remove the cause of the wet
Sometimes inactive	<ul style="list-style-type: none"> ●Improper area setting 	<ul style="list-style-type: none"> ●Relocate the sensor to appropriate position ●Use a BCW-401 (optional) and adjust the angle setting
	<ul style="list-style-type: none"> ●Detection window is soiled with dust 	<ul style="list-style-type: none"> ●Remove the dust and soil
	<ul style="list-style-type: none"> ●Low battery 	<ul style="list-style-type: none"> ●Change battery
	<ul style="list-style-type: none"> ●Low voltage 	<ul style="list-style-type: none"> ●Correct power supply
Activated without flame	<ul style="list-style-type: none"> ●Large electrical noise source such as a radio station or high-voltage wire nearby 	<ul style="list-style-type: none"> ●Relocate the sensor
	<ul style="list-style-type: none"> ●Unexpected ultraviolet rays nearby (Ref : 2, ATTENTION) 	<ul style="list-style-type: none"> ●Remove the origin of the ultraviolet rays, interrupt ultraviolet rays, or relocate the sensor
	<ul style="list-style-type: none"> ●Sensor inside is wet by condensation etc. 	<ul style="list-style-type: none"> ●Dry out sensor inside, and remove the cause of wet
The alarm LED flashes and buzzer sounds (5sec./once)	<ul style="list-style-type: none"> ●Low battery (Low battery alarm) 	<ul style="list-style-type: none"> ●Change battery immediately
The alarm LED lights on but buzzer does not sound	<ul style="list-style-type: none"> ●Buzzer "OFF" 	<ul style="list-style-type: none"> ●Buzzer "ON"
The alarm LED and buzzer works but the connected devices are inactive (when wired)	<ul style="list-style-type: none"> ●Poor contact output connection or broken wire 	<ul style="list-style-type: none"> ●Check the wiring or connection
	<ul style="list-style-type: none"> ●The connected unit's trouble 	<ul style="list-style-type: none"> ●Check the connected unit

Maintenance

- When the sensor is soiled, clean the cover with a soft cloth moistened with a small amount of cleaning solution.
- Check operation once a week.
Do not fail to check operation whenever a furniture in the place is moved.
- When low battery alarm sounds, change battery for new one immediately.
If it is left, it could cause inactiveness of the sensor.

When detector elements are stained, spray alcohol to the elements and remove the stain. Do not use such chemicals as mild detergent, thinner or benzine to clean the detector elements. When housing is stained, clean it with a soft cloth.

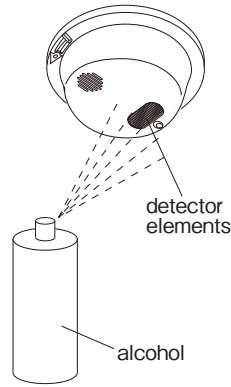

11 EXTERNAL DIMENSIONS

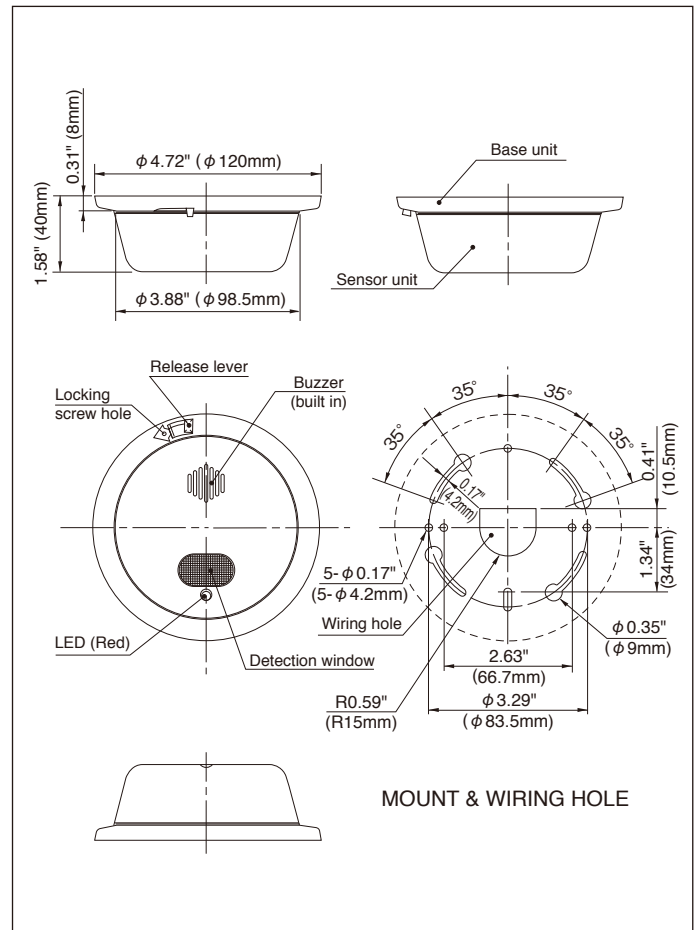

10 SPECIFICATIONS

Model No.	FS-1000E
Detection system	Ultraviolet rays detection (Detected wave length 180 to 260nm)
Detection distance	33ft. (10m) [2.75" (7cm) lighter flame, in front]
Sensitivity adjustment	Detection sensitivity (H [100%], L [50%]) Detection timer (1sec., 6sec., 15sec., 30sec.)
Power supply	●Type-AA alkaline battery(not included) ●External power supply 9 to 30V DC with polarity
Power consumption	Stand by : 50 μ A Max. using battery power supply 5mA Max. using external power supply Alarm : 50mA Max. when buzzer sounds (Excluding the current draw for power output through terminal (3) & (4))
LED	Indication : Red LED Alarm : Flashing every 0.2sec. during off-delay 10sec. Low battery : Light on 0.1sec. every approx. 5sec.
Buzzer	Alarm : Sounds intermittently every 0.2sec. during off-delay 10sec. Low battery : Sounds 0.1sec. intermittently every approx. 5sec. Volume : 80dB or more 3.3ft. (1m) ahead (Silent setting is available by cutting internal jumper line)
External output	NPN open collector output (Useful as an output with voltage when external power is used) 30V DC 50mA offdelay 10sec. continuous output
Wiring	Terminals
Ambient temp. range	+14°F to +140°F (-10°C to +60°C) without condensation Battery performance may decrease under +32°F (0°C) or beyond +104°F (+40°C)
Installation	Indoor (ceiling or wall mount)
Weight	Approx. 7oz (200g) including battery (accessory) 1.8oz (50g)
External dimensions	$\phi 4.72"$ (120mm) \times H 1.58" (40mm)
Appearance	ABS resin (white)
Accessories	●Battery case for type-3 \times 2pcs, \times 1 ●Type-AA alkaline battery LR-6 \times 2 ●Sensor locking screw $\phi 3 \times 6$, \times 1 ●Tapping screw $\phi 4 \times 25$, \times 2
Option	●Ceiling/wall mount attachment BCW-401 (variable attachment)

MOUNT & WIRING HOLE

OPTION

- Ceiling/wall mount attachment (variable attachment)

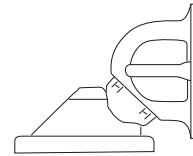

[BCW-401]

Limited Warranty :

TAKEX products are warranted to be free from defects in material and workmanship for 12 months from original date of shipment. Our warranty does not cover damage or failure caused by Acts of God (including inductive surge by lightning), abuse, misuse, abnormal usage, faulty installation, improper maintenance or any repairs other than those provided by TAKEX. All implied warranties with respect to TAKEX, including implied warranties for merchantability and implied warranties for fitness, are limited in duration to 12 months from original date of shipment. During the Warranty Period, TAKEX will repair or replace, at its sole option, free of charge, any defective parts returned prepaid. Please provide the model number of the products, original date of shipment and nature of difficulty being experienced. There will be charges rendered for product repairs made after our Warranty period has expired.



In Japan
Takenaka Engineering Co., Ltd.
 83-1, Gojo-sotokan, Higashino,
 Yamashina-ku, Kyoto 607-8156, Japan
 Tel : 81-75-501-6651
 Fax : 81-75-593-3816
 http : // www. takex-eng. co. jp /

In the U.S.
Takex America Inc.
 3350, Montgomery Drive
 Sant Clara, CA 95054, U.S.A.
 Tel : 408-747-0100
 Fax : 408-734-1100
 http : // www. takex. com

In Australia
Takex America Inc.
 4/15 Howleys Road, Notting Hill,
 VIC, 3168
 Tel : +61 (03) 9544-2477
 Fax : +61 (03) 9543-2342

In the U.K.
Takex Europe Ltd.
 Takex House, Aviary Court, Wade Road,
 Basingstoke, Hampshire. RG24 8PE, U.K.
 Tel : (+44) 01256-475555
 Fax : (+44) 01256-466268
 http : // www. takexeurope. com