

# TAKEX

## Instruction Manual



## PASSIVE INFRARED SENSOR

PA-7100E

**ROUND TYPE**

**360° COVERAGE**

Thank you for purchasing this TAKEX product.

This sensor will provide long and dependable service when properly installed.

Please read this Instruction Manual carefully for correct and effective use.

Please Note : This sensor is designed to detect intrusion and to initiate an alarm; it is not a burglary-preventing device. TAKEX is not responsible for damage, injury or losses caused by accident, theft, Acts of God (including inductive surge by lightning), abuse, misuse, abnormal usage, faulty installation or improper maintenance.

## 1. DESCRIPTION

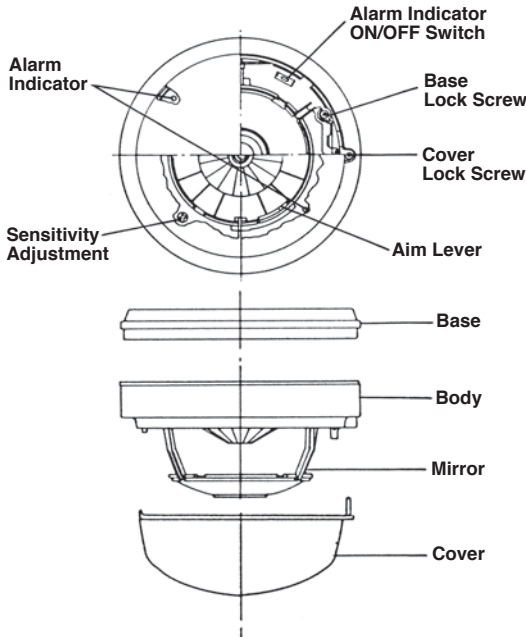

## 2. COVERAGE AND RANGE

ROUND TYPE/PA-7100E

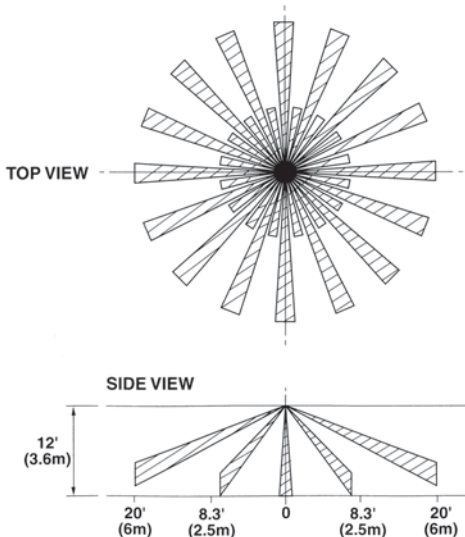

## 3. DO'S AND DON'T'S

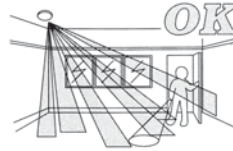

- Install the sensor in a direction such that intruders are more likely to cross the protection zones, rather than approach head on.

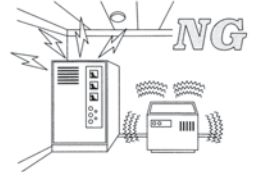

- Do not install in a site which is subject to electrical noise.

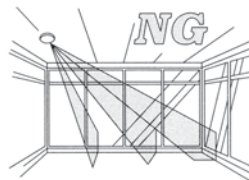

- Avoid headlight beams, direct sunlight or intense reflections on the sensor or the protection zone.



- Do not install the sensor outdoors. (indoor only)

## 4. INSTALLATION

1. Detach cover.

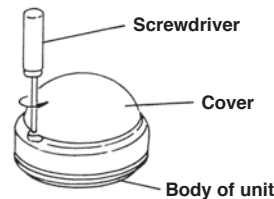

2. Detach base.

Turn the sensor unit counter-clockwise and it will come off easily.

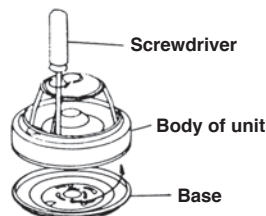

3. Install the base on the ceiling.

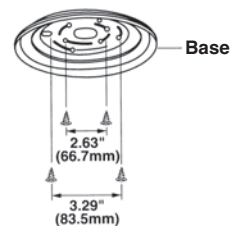

4. Connect wires, set the protection direction and attach the unit body. Turn the unit body clockwise to attach it.

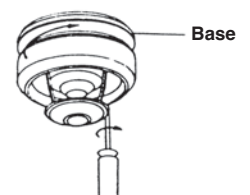

5. Adjust the coverage by zone locator.
6. Attach the cover after sensitivity adjustment.

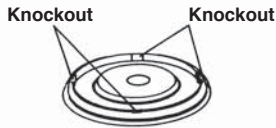
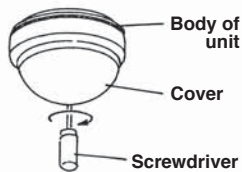

\* Break the knockouts on the back of base for exposed wiring.

## 5. WIRING

[Terminal arrangement-base]

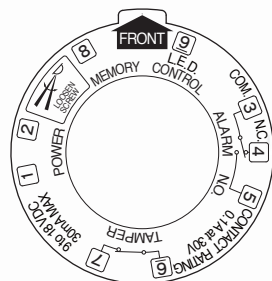

- 1 2 **Power Input**  
Input Voltage is 9 - 18 V-DC. NON-POLARITY
- 3 4 5 **Alarm output**  
When no Alarm is present, there is continuity between COM-NC.  
When an activation occurs, there is continuity between COM-NO.

- 6 7 **Tamper output**  
When the cover is attached, there is continuity.  
When the cover is removed, there is no continuity.
- 8 Refer to "MEMORY FUNCTION"
- 9 Refer to "LED CONTROL"

[Basic connection]

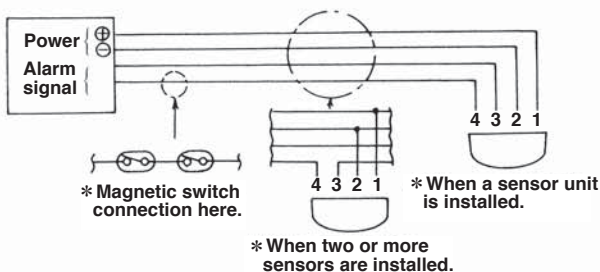

Allow at least 1 minute warm-up time after power ON.  
In the meantime the alarm indicator is flickering. The sensor unit comes to armed condition after the indicator finishes flickering.

## 6. COVERAGE DESCRIPTION

The coverage can be changed vertically and horizontally by moving mirror body and base.  
Adjust the angle as application demands.

### Ceiling mount

Horizontally adjustable range :  
 $\pm 12^\circ$  by base

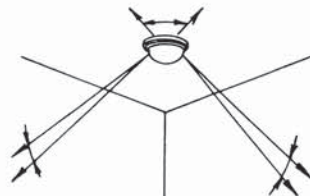

Vertically adjustable range :  
 $\pm 5^\circ$  by mirror body



## 7. ADJUSTMENT OF THE FIELD OF VIEW

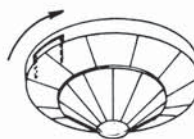

- 1) Turn the aim lever clockwise to lock.

\*  $\pm 12^\circ$  by loosening screw on base

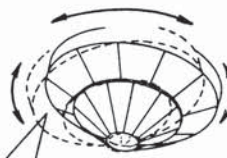

\*  $\pm 5^\circ$  by pushing mirror edge

- 2) Adjust the coverage so that LED is visible through mirror from location to be protected.
- 3) Gently push the lever to return to its original position.

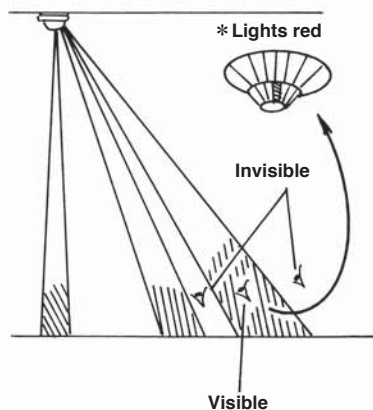

Red light is visible in area of detection.

## 8. OPERATION CHECK

- 1) When installation is completed, walk test in the protected area to check if an alarm is initiated.  
Check alarm indicator and control panel for sensor operation.
- 2) After correct operation has been confirmed, use the switch inside the sensor unit to turn off the alarm indicator, if required.

## 9. SENSITIVITY ADJUSTMENT

If the sensitivity is found to be too high as a result of the walk test, set it to an adequate level by repeating the test with the sensitivity adjustment turned gradually toward LOW.



## 10. SWITCH

- ON** : The indicator lights when an alarm is initiated.
- OFF** : The indicator does not light when an alarm is initiated.

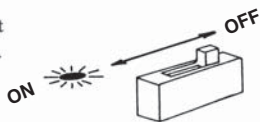

## 11. MEMORY FUNCTION

Is a function that can confirm later which sensor triggered an alarm when two or more units are installed on the same alarm signal zone.

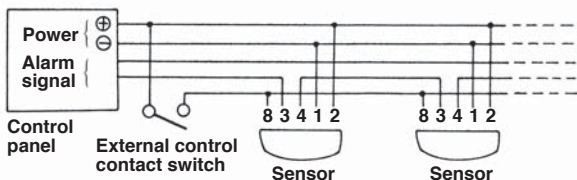

Wire terminal ⑧ (MEMORY CONTROL) and set up an external control contact, which turns ON/OFF with power ⊕ in addition to wiring of power and of alarm signal.

Note : Connect terminal ⑧ if memory function is to be used.

### •How to use

Turn the SW. ON for protection condition (when you intend to store alarm memory).

Turn the SW, OFF for dis-armed condition (when you check the existence of alarm under protection condition.)

A sensor that has initiated an alarm in protection condition (SW.-ON) lights its alarm indicator continuously when protection is released (SW-OFF).

When it returns to protection condition (SW-ON), memory is reset and alarm indicator goes out.

Note : Memory indication lights regardless of alarm indicator switch.

## 12. LED CONTROL

LED Control functions as remote control of alarm indicator.

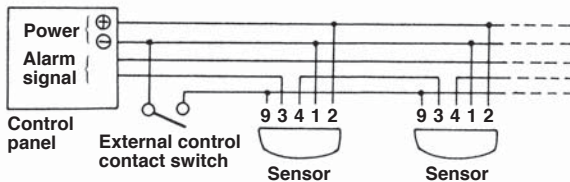

Wire terminal ⑨ (LED CONTROL) and set up an external control contact, which turns ON/OFF with power ⊕ in addition to wiring of power and of alarm signal.

Note : Connect terminal ⑨ only if remote control of alarm indicator is to be used.

### •How to use

Turn the alarm indicator switch OFF.

When external switch is turned ON, the alarm indicator lights at alarm.

When external switch is turned OFF, the alarm indicator does not light.

## 13. EXTERNAL DIMENSIONS

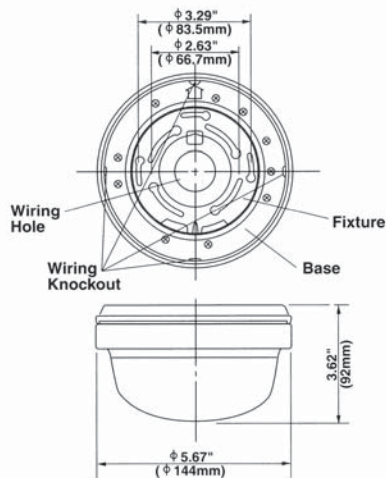

## 14. SPECIFICATIONS

Model	PA-7100E
Area	Round type (360° COVERAGE)
Range	40' (12m) dia at 12' (3.6m) height
Number of sensitivity zone	264 (33 pairs)
Mounting position	Indoor ceiling within 12' (3.6m) height
Supply voltage	9V to 18V DC Non polarity (Class 2 Only)
Power consumption	30mA Max (Class 2 Only)
Alarm output	0.1A, 30V 1C (SPDT) Reset : 2 sec. ± 1 sec.
Tamper output	0.1A, 30V 1b (SPST)
Memory function	Control at terminal 8 : Lights up for memory indication
LED control	Control at terminal 9 or built-in switch
Ambient temperature range	+ 14° F to + 122° F ( - 10° C to + 50° C)
Relative humidity	85% ± 5% (at 30° C)
Weight	11.6oz (330g)



# 15. TROUBLESHOOTING

Analyze possible problems according to the following table. If normal operations cannot be restored by this means, contact either the dealer from whom you bought the unit or PULNiX.

Trouble	Check	Corrective action
Does not operate at all. (Alarm Indicator does not light.)	Either power is off (including broken cable) or power voltage is too low.	Check the power cable and adjust power voltage properly.
	Is there an obstacle in front of the detection area?	Remove the object.
	Is detection area adjustment correct?	Readjust the detection area setting.
Intermittent misoperation.	Is detection area adjustment correct?	Readjust the detection area so that persons are detected in all areas.
	Is power voltage unstable?	Stabilize the power voltage.
	Does the detection range exceed 40 ft (12m) dia	Reposition so that the range is less than 40 ft (12m) dia
Operates when no person has passed.	Is there any moving object or a rapid temperature change source in the detection area?	Remove the object considered to be the cause.
	Is there a source of electrical noise (broadcasting station, amateur radio, etc.) nearby?	Change the installation location.
	Is there any strong reflection from a sunray or direct light hitting the unit?	Change the installation location. Shield sunrays with a blind.
	Is the detector reacting to passersby outside?	Readjust the detection area.
The Alarm Indicator lights, but the controller does not operate.	Poor contact output connection, or broken wire or short circuit.	Check the wiring using a tester.
	Contact output is not working.	Check the contact output terminal using a tester.
	Is the controller operation normal?	Check the controller.

This PASSIVE INFRARED SENSOR is designed to detect infrared energy variations caused by the presence of human body. Therefore, note that similar variations in conditions in protected area, due to other reasons, may cause the sensor to create an alarm as it is unable to distinguish between sources.

The power supply used with this unit must have a minimum 4 hour stand-by power capability.

Regular maintenance and inspection (at least annually) by installer and frequent testing by the user are vital to continuous satisfactory operation of any alarm system.

### Limited Warranty :

TAKEX products are warranted to be free from defects in material and workmanship for 12 months from original date of shipment. Our warranty does not cover damage or failure caused by natural disasters, abuse, misuse, abnormal usage, faulty installation, improper maintenance or any repairs other than those provided by TAKEX. All implied warranties with respect to TAKEX, including implied warranties for merchantability and implied warranties for fitness, are limited in duration to 12 months from original date of shipment. During the Warranty Period, TAKEX will repair or replace, at its sole option, free of charge, any defective parts returned prepaid. Please provide the model number of the products, original date of shipment and nature of difficulty being experienced. There will be charges rendered for product repairs made after our Warranty Period has expired.



In Japan  
**Takenaka Engineering Co., Ltd.**  
 83-1, Gojo-sotokan, Higashino,  
 Yamashina-ku, Kyoto 607-8156, Japan  
 Tel : 81-75-501-6651  
 Fax : 81-75-593-3816  
<http://www.takex-eng.co.jp/>

In the U.S.  
**Takex America Inc.**  
 3350, Montgomery Drive  
 Sant Clara, CA 95054, U.S.A.  
 Tel : 408-747-0100  
 Fax : 408-734-1100  
<http://www.takex.com>

In Australia  
**Takex America Inc.**  
 4/15 Howleys Road, Notting Hill,  
 VIC, 3168  
 Tel : +61 (03) 9544-2477  
 Fax : +61 (03) 9543-2342

In the U.K.  
**Takex Europe Ltd.**  
 Takex House, Avairy Court, Wade Road,  
 Basingstoke, Hampshire. RG24 8PE, U.K.  
 Tel : (+44) 01256-475555  
 Fax : (+44) 01256-466268  
<http://www.takexeurope.com>