

# TAKEX PHOTOELECTRIC BEAM SENSOR

PXB- 50F:OUTDOOR 165ft ( 50m)

PXB-100F:OUTDOOR 330ft (100m)

PXB-200F:OUTDOOR 660ft (200m)

## Instruction Manual

Thank you for purchasing this product.

Read this instruction manual before using the product to make sure that you use it correctly.

This device is an opposed type photoelectric beam sensor that consists of a photo transmitter that transmits infrared light, and a photo receiver for the transmitted light, as shown in the illustration on the right.

The infrared light transmitted from the transmitter expands in a cone shape, while the light beams enter the receiver.

The straight line that connects the transmitter with the receiver is the detection line.

If the detection line is obstructed (light is obstructed for more than 0.05 – 0.7 seconds), the receiver detects this break in the light beams, and outputs a signal.

In order to ensure that the detection line has sufficient margin of sensitivity, adjust the direction of the light beams before placing the system into operation.

Providing sufficient margin of sensitivity reduces the occurrence of malfunction caused by dense fog, heavy rain, frost, snow, and other such weather conditions.

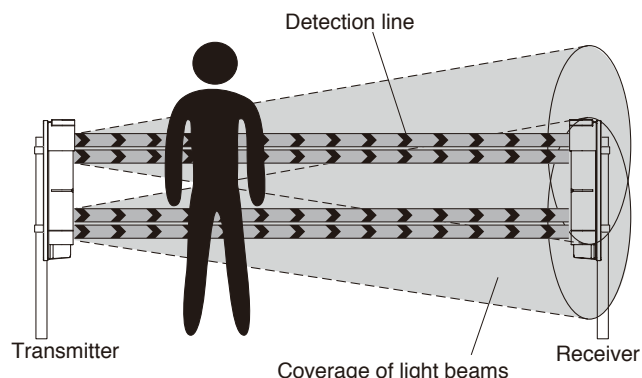

## Main Features

### (1) DOUBLE MODULATION



Double modulated beams are designed to distinguish the external lights. It increases the reliability in the outdoor security system.

### (2) WIDE BEAM



The pitch between upper beam and lower one is widened more than old models. False alarm by birds and falling leaves reduces drastically.

### (3) QUAD HIGH POWER BEAM



The beam power is 100 times of the minimum requirement. The beam distance is 10 times of the described specification. This high power beam also realizes the reliability against the harsh conditions like fog, snow, heavy rain.

### (4) LOW CURRENT CONSUMPTION



50% less than remaining models. The battery size may reduce, wiring diameter may lessen, installation cost may decrease.

### (5) ECOLOGY



RoHS adapted – Environment friendly. Free from Lead, Mercury, Cadmium, Hexavalent chromium, Polybrominated biphenyl, Polybrominated diphenyl ether.

### (6) INSECT/WATER PREVENT



Anti-insect bushing and special gasket enable IP65 rated tight housing.

### (7) DRIP-PROOF HOUSING



Prevents rain and snow from streaming down the front side of housing, helping to avoid false alarm.

### (8) DUAL RING SIGHT



Enables better and clear view for easy beam alignment.

### (9) TARGET COLOR



The vivid color of the internal structure can be recognized easily from the far end in the beam alignment procedure. The color differs between a transmitter and a receiver which helps easy installation and checking.

### (10) INCREASED ANGLE ADJUSTMENT ALLOWANCE



Vertically  $\pm 20^\circ$  compared with previous version. It may adapt to the slope installation flexibly.

### (11) WIRELESS ALIGNMENT CHECKER



Enables easy and accurate beam alignment. (Sold separately)

### (12) LIGHTNING/SURGE PROTECTION



Minimize the damage by the induced lightning through wirings. It may stand 10000V under normal mode, 15000V under common mode.

# — TABLE OF CONTENTS —

1	PRODUCT COMPONENTS	
1-1	PARTS DESCRIPTION.....	2
1-2	ACCESSORIES.....	2
1-3	NAMES OF OPERATION SECTION.....	3
2	PRECAUTIONS.....	3
3	PRECAUTIONS	
3-1	PROTECTION DISTANCE AND RANGE OF LIGHT BEAM COVERAGE.....	4
3-2	MOUNTING HEIGHT.....	4
3-3	OPTICAL AXIS ADJUSTMENT RANGE.....	5
3-4	EXAMPLE OF PRACTICAL APPLICATION.....	5
4	INSTALLATION METHOD	
4-1	WALL INSTALLATION METHOD.....	6
4-2	POLE INSTALLATION METHOD.....	7
5	WIRING METHOD	
5-1	POSITION AND RATING OF TERMINALS.....	8
5-2	WIRING DISTANCE BETWEEN SENSOR AND POWER SUPPLY.....	8
5-3	WIRING DISTRIBUTION DIAGRAM (WIRING DIAGRAM).....	8
6	OPTICAL AXIS ADJUSTMENT	
6-1	NAMES AND FUNCTIONS OF OPTICAL AXIS ADJUSTMENT PARTS.....	9
6-2	OPTICAL AXIS ADJUSTMENT USING THE ALIGNMENT MECHANISM.....	10
	• Optical Axis Fine Adjustment Using the Sound Check.....	11
	• Optical Axis Fine Adjustment Using the Monitor Output Voltage.....	12
	• Optical Axis Fine Adjustment Using the Alignment Wireless Checker (Sold Separately).....	12
7	OPERATION CHECK.....	13
8	EXPLANATION OF FUNCTIONS	
8-1	SOUND CHECK FUNCTION.....	13
8-2	RESPONSE TIME ADJUSTMENT FUNCTION.....	13
8-3	UPPER/LOWER CHANGEOVER FUNCTION.....	14
8-4	LIGHT SENSITIVITY SIGNAL FUNCTION.....	14
8-5	EXTERNAL ENVIRONMENT DIAGNOSTIC FUNCTION.....	14
8-6	ALIGNMENT WIRELESS CHECKER CONNECTION FUNCTION.....	14
9	TROUBLESHOOTING.....	14
10	SPECIFICATIONS.....	15
11	EXTERNAL DIMENSIONS Unit: inch (mm).....	16

## 1 PRODUCT COMPONENTS

This section describes the contents of the product package and the names and functions of the parts that appear in this instruction manual.

### 1-1 PARTS DESCRIPTION

• Check that the following transmitter, receiver, and accessories are included in the box when you first unpack the product.

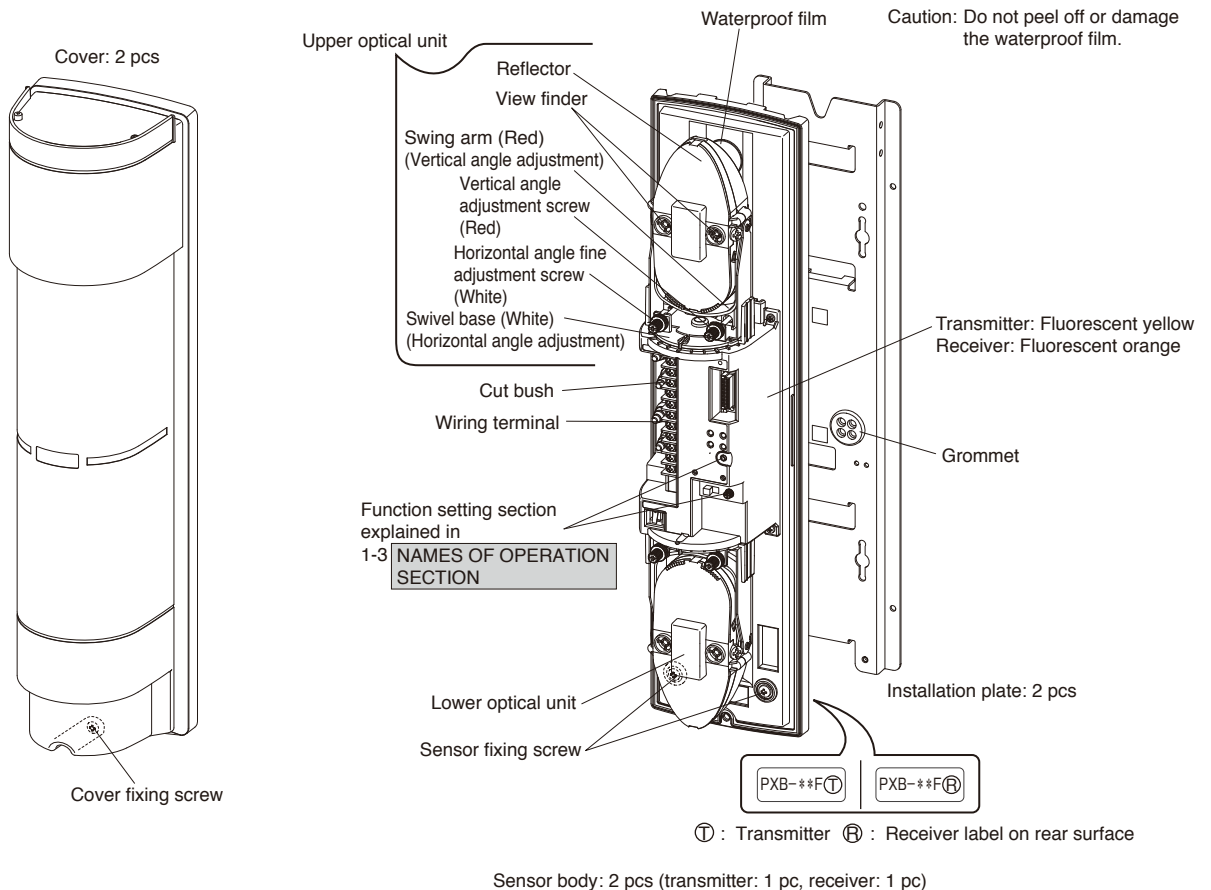

### 1-2 Accessories

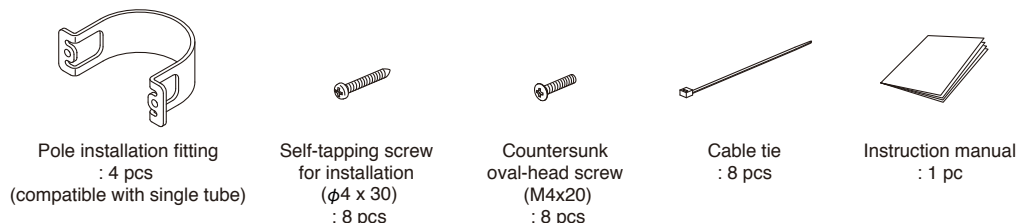

## 1-3 NAMES OF OPERATION SECTION

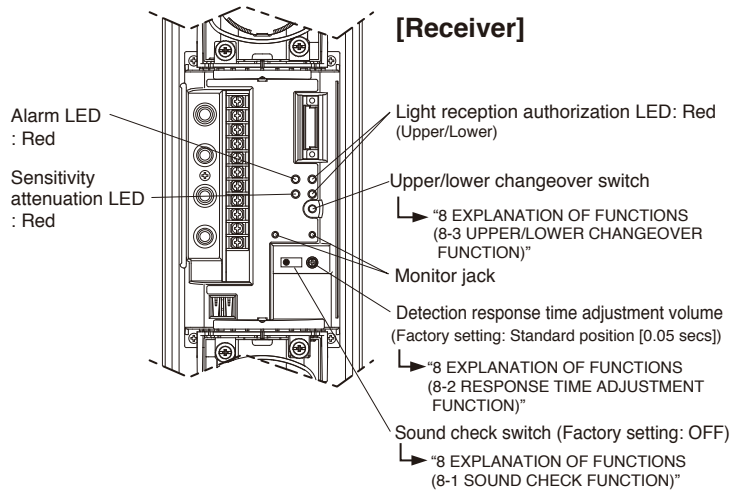
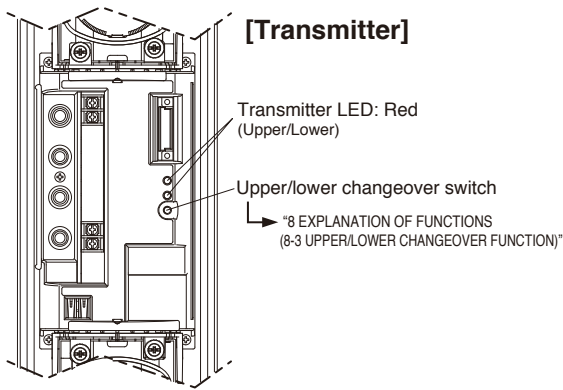

## 2 PRECAUTIONS

• This manual describes the precautions to be observed for safe operation of this device by classifying them into the following categories. As these are important, be sure to read and strictly observe them.

When using multi-level protection, use sensors of same model for both upper and lower sensors.

Using these sensors together with sensors from different series (e.g. PB-IN-HFA) may cause interference between the sensors.

### Description of the Display

**Warning** Indicates information that if ignored and the device is handled incorrectly, may result in death or serious injury.

**Caution** Indicates information that if ignored and the device is handled incorrectly, may result in injury or damage to property alone.

This symbol indicates a prohibited action, with the specific action shown near the symbol. **Example:** Do not disassemble

Indicates the useful information.

### Warning

Do not use the sensors powered with a voltage level other than the indicated power supply voltage specified (between 10 to 30V DC). Doing so may cause a fire or electrical shock.

Do not connect a device that exceeds the capacity shown to the output contact of this device. Doing so may cause a fire or electrical shock.

Do not touch the terminal section with wet hands. Doing so may cause an electrical shock.

Do not disassemble or modify this device. Doing so may cause a fire, electrical shock, or malfunction of the device.

If smoke or an abnormal odor or sound is found, leaving it unattended may cause a fire or electrical shock. Immediately turn off the power to the device and confirm that the abnormal state has been corrected, and then ask the place of purchase for repair.

### Caution

Consider the rated protection distance for each device, and use within the rated distance.

Do not install this device in a location that cannot support its weight. Doing so may cause the device to fall and cause an injury or malfunction of the device.

Do not install the device as shown below. If may cause erroneous detection or detection failure.

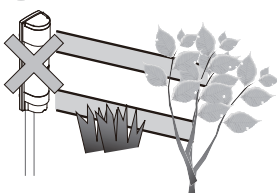

• Installation in locations shaded by trees etc.

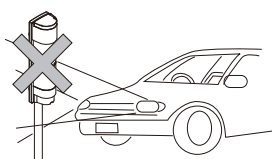

• Installation in location where strong light such as sunlight or light from vehicle headlights can directly enter the optical axis

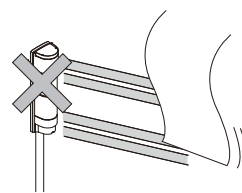

• Installation in areas where objects that move (the laundry etc) can obstruct the optical axis

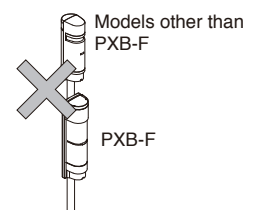

• Using PXB-F together with other models

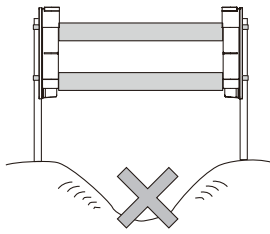

- Installation on uneven ground

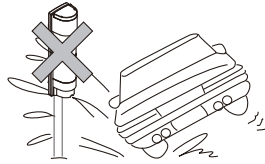

- Installation in locations where the device may be splashed by dirty water or direct sea spray

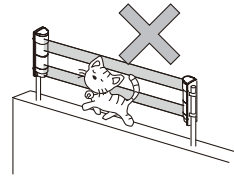

- Installation directly above a wall

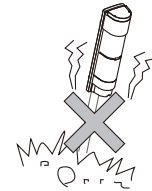

- Installation in an unstable, wobbling location

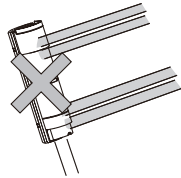

- Slanted installation

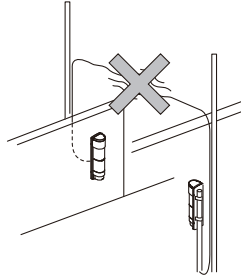

- Overhead wiring

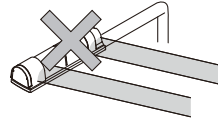

- Horizontal installation

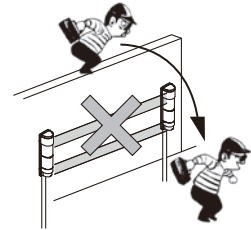

- Installation close to a wall



### Cautions when using the outdoor photoelectric beam sensor (Daily maintenance)

1. In areas where there are trees or weeds, the photoelectric beams may get obstructed by overgrown branches or leaves. As this may cause erroneous detection, be sure to trim down leaves and branches according to the growth of the plants. Furthermore, the photoelectric beams may get obstructed by swaying branches or leaves due to wind. Keep in mind the swaying of leaves and branches when trimming them.
2. Bine plants may wrap around the photoelectric beam sensors causing erroneous detections. Therefore, be sure to prune such plants regularly.
3. Insects, bird droppings, or other natural phenomena may also soil the sensors causing erroneous detection. Be sure to clean the sensors regularly.

## 3 PRECAUTIONS

In order to use these sensors correctly, read thoroughly this instruction manual and select the mounting position and protection distance.

### 3-1 PROTECTION DISTANCE AND RANGE OF LIGHT BEAM COVERAGE

As the infrared light leaves the transmitter, it expands into conic shape light beams. The optical axis is in the center of the light beams. Arrange the reflector so that the device on the opposite side is in the center of the light beams.



CORRECT

If the optical axis (center of the light beams) is aligned correctly, a detection line with sufficient margin of sensitivity is formed.

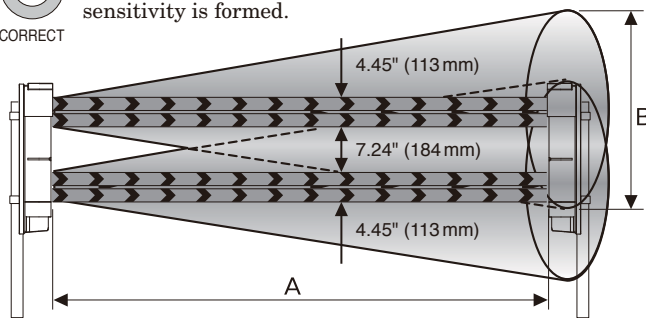

A: Protection Distance	B: Coverage of light beam
165ft (50 m)	Approx. 4ft (1.2 m)
330ft (100m)	Approx. 8ft (2.4 m)
660ft (200m)	Approx. 16ft (5.0 m)



WRONG

If the optical axis is not aligned correctly, there will be insufficient margin of sensitivity even if the receiver is at the center of the light beams, making the system more susceptible to adverse effects of the environment resulting in a malfunction.

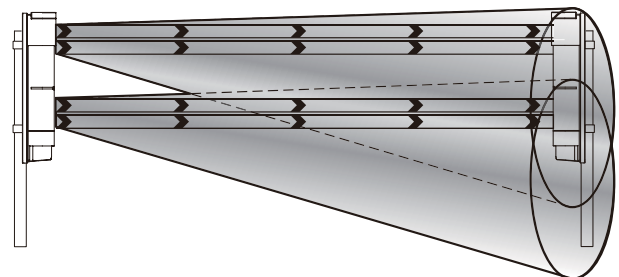

### 3-2 MOUNTING HEIGHT

As these sensors are designed to detect humans, install so that the center of the sensors are at a height of approximately 2.6ft (0.8m) from the ground when installing both on a wall and on a pole.



WRONG



CORRECT

WRONG

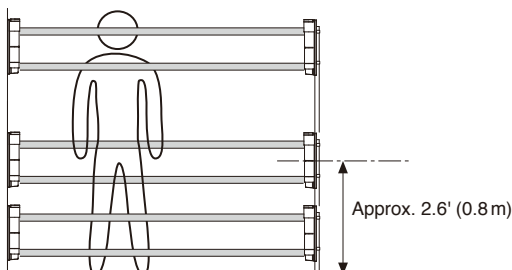

Approx. 2.6' (0.8m)



CORRECT



WRONG

Installing so that the center of the sensor is approximately 2.6ft (0.8m) from the ground means that the protection line is at waist height for humans, enabling reliable detection.

If the installation position is too high or too low, the protection line will be above shoulder height or below knee height, making it more difficult for reliable detection.

### 3-3 OPTICAL AXIS ADJUSTMENT RANGE

• Refer to the diagram below, and install the sensors within the optical axis adjustment range. (Photoelectric beams are drawn in simplified form)

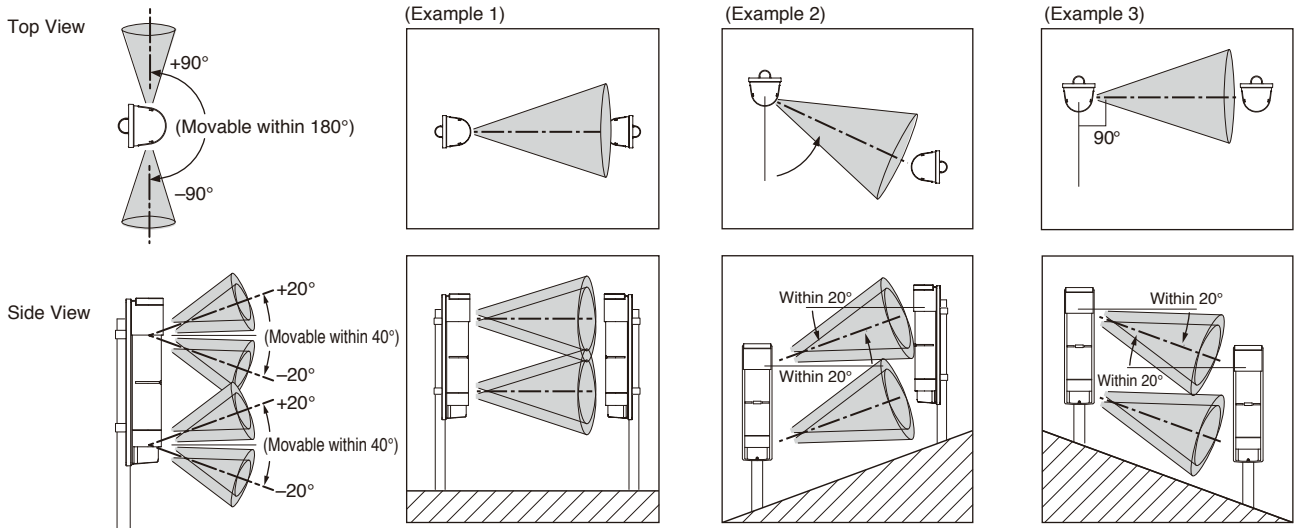

### 3-4 EXAMPLE OF PRACTICAL APPLICATION

• In order to minimize the occurrence of malfunctions, refer to the protection diagram below for optimal operation.  
 Using the sensors incorrectly may cause malfunction. (Light beams are drawn in simplified form)

- When using multi-stacked protection or install straight line protection at multiple spans, use a sensor for which the modulation frequency can be switched. (EX : PXB-50HF)
- For the installation methods not described in the instruction manual, contact the place of purchase or TAKEEX.

#### Dos and Don'ts

##### ● Straight Line Protection (2spans)

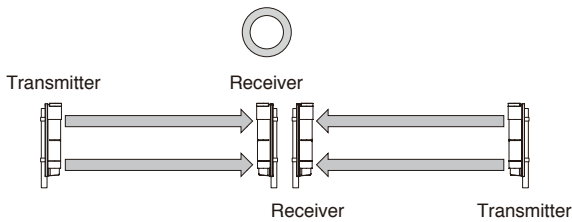

##### ● Multi stacked protection

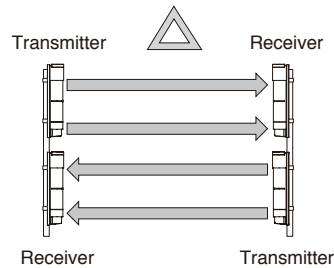

● Check if there is a lost alarm due to light reception from other transmitter.

● Don't install transmitters in the same direction for double stacked protection or straight line protection with multiple spans to avoid malfunction or lost alarm by interference.

Don't install transmitters in the same direction for straight line protection.

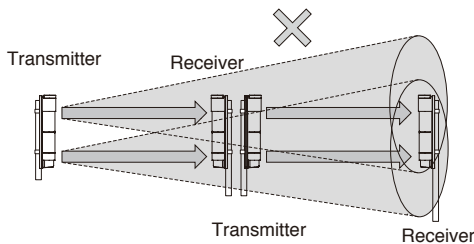

Don't install transmitters with more than three spans in straight line protection.

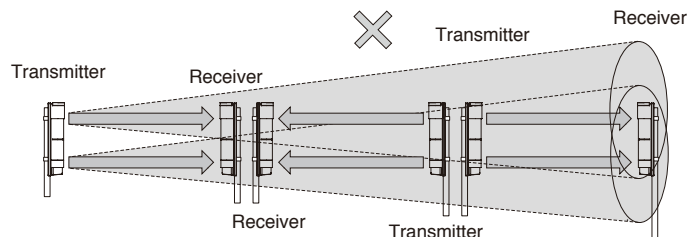

Don't install transmitters in the same direction for multi stacked protection.

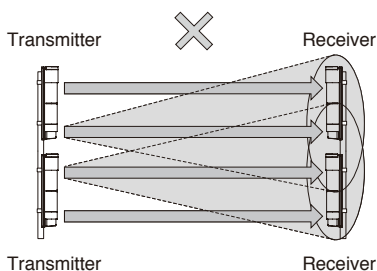

Don't install transmitters for multi stacked protection with multiple spans

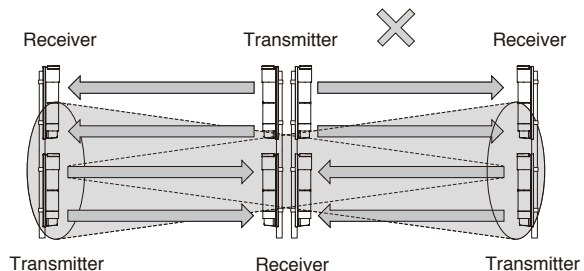



# 4 INSTALLATION METHOD

## 4-1 WALL INSTALLATION METHOD

- 1**
- Loosen the cover fixing screw, and remove the cover.
  - Loosen the sensor fixing screws (2 pcs), and remove the sensor body.

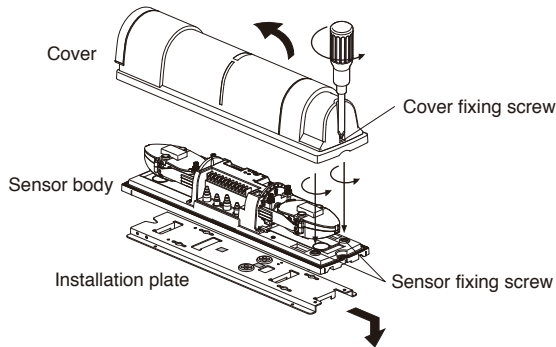

- 2**
- Place the installation plate in position, then ensure that the space shown by the dotted lines is allocated before marking the positions of the screws.

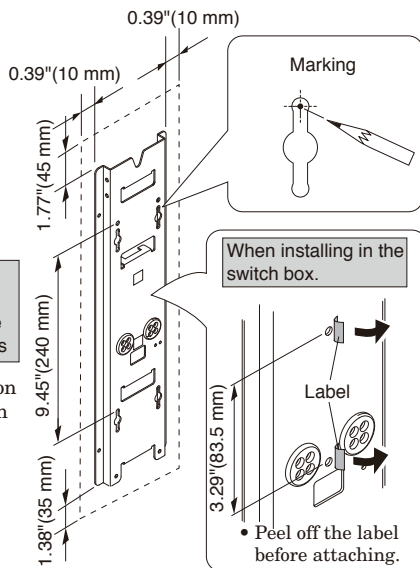

When installing using the same installation holes as those for the PB-F/PB-IN-HF series

- Use the installation holes of 9.45" pitch (240 mm).

- 3**
- Tighten the self-tapping screws for installation (4 pcs) in the marking locations up to 15 mm of the screw body.
  - Pass the wiring material through the grommet.
  - Attach the installation plate and secure it by tightening the screws.

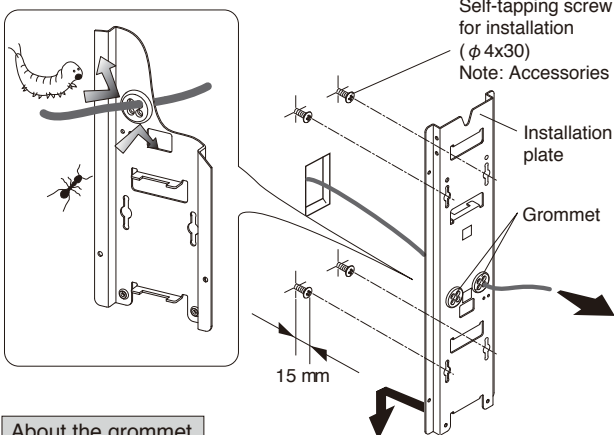

### About the grommet

This work is required as an insect-proof and drip-proof countermeasure for the sensor exterior.

- Note 1: For wiring with an external diameter of  $\phi 0.12"$  (3 mm) to  $\phi 0.24"$  (6 mm), break the membrane by pressing it through the recess.
- Note 2: For wiring with an external diameter exceeding  $\phi 0.24"$  (6 mm), cut off the section shown by the dotted lines in the drawing below using nippers or equivalent tools. Be sure to caulk the cut section as an insect-proof countermeasure.

- 4**
- Trim down the diameter of the cut bush so that it is to a diameter smaller than that of the diameter of the wiring.
  - Pass the wiring through the cut bush.
  - Use the sensor fixing screws (2 pcs) to fix the sensor body to the installation plate.

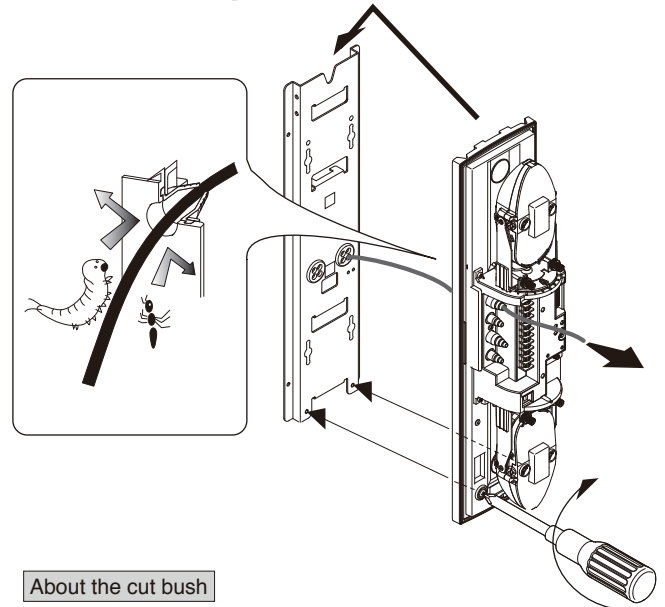

### About the cut bush

This work is required as an insect-proof and dust-proof countermeasure for the sensor exterior.

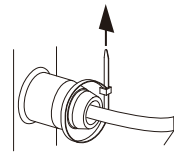

Note: If there is a gap between the wire and the cut bush, use the cable tie included to tighten and close the gap.

- 5**
- Refer to section **5 WIRING METHOD** to connect the wiring. Refer to section **6 OPTICAL AXIS ADJUSTMENT** to adjust the optical axis.

- 6**
- Attach the cover to the sensor body, and fix it in place using the cover fixing screws.
  - Attach bird stoppers to the cover as and when needed.

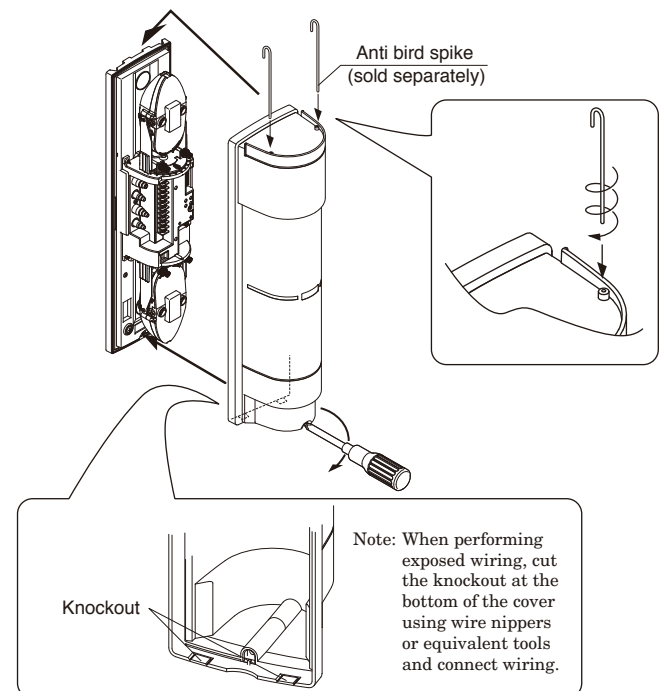

## 4-2 POLE INSTALLATION METHOD

Note: This device can be attached to a pole with diameters of 1.65" ( $\phi 42$  mm) to 1.95" ( $\phi 49$  mm).

- 1**
- Loosen the cover fixing screws, and remove the cover.
  - Loosen the sensor fixing screws (2 pcs), and remove the sensor body.

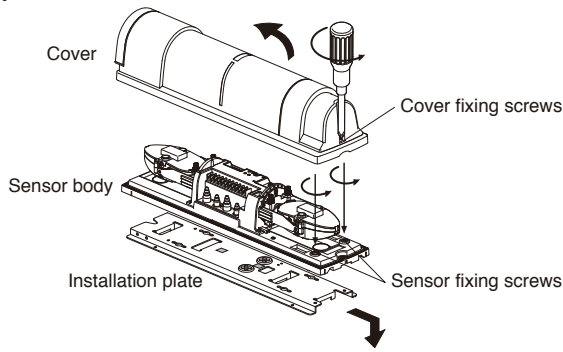

- 2**
- Attach countersunk oval-head screws to the pole installation fittings. (Secure it to the end of the pole)
  - Pass the wiring pulled from the pole through the grommet.
  - Fix the installation plate to the pole using the installation fittings.

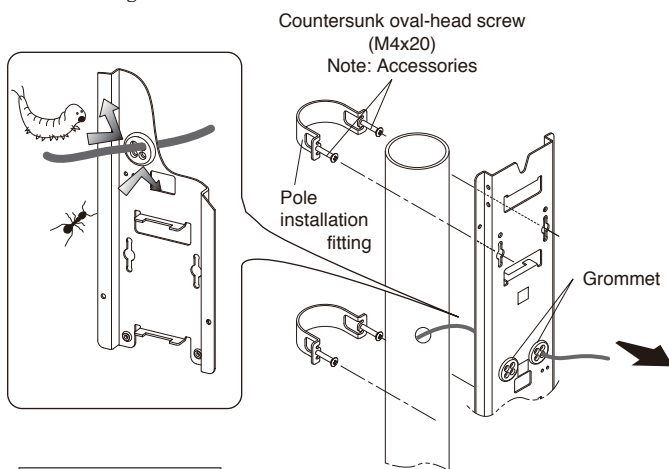

### About the grommet

This work is required as an insect-proof and drip-proof countermeasure for the sensor exterior.

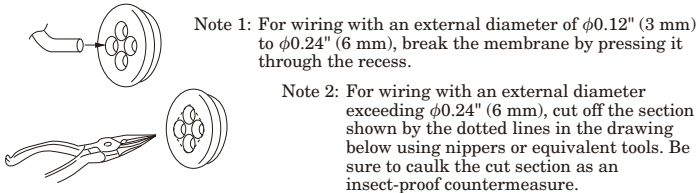

### Back to back pole installation

- Pass the wiring material through the grommet.
- Install the pole installation fittings as shown in the diagram, and then fix the installation plates.

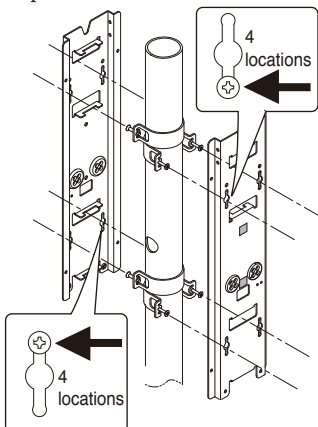

### Installation to a pole exceeding $\phi 1.95"$ ( $\phi 49$ mm)

- Drill a pilot hole of  $\phi 0.13"$  ( $\phi 3.3$  mm) on the pole, and then tap an M4 hole.
- Note: Be extremely careful when drilling a pilot hole on the pole.
- Peel off the label and attach the plate using screws.

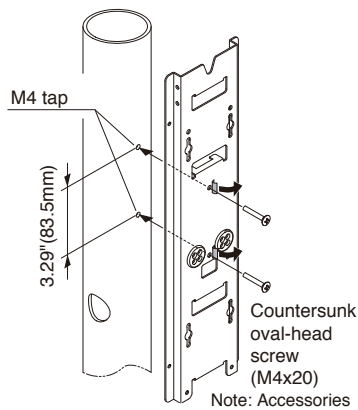

- 3**
- Trim down the diameter of the cut bush so that it is to a diameter smaller than that of the diameter of the wiring.
  - Pass the wiring through the cut bush.
  - Use the sensor fixing screws (2 pcs) to fix the sensor body to the installation plate.

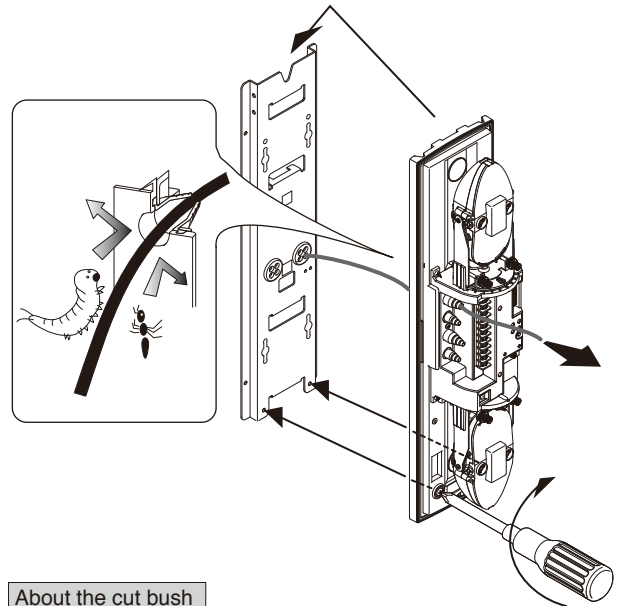

### About the cut bush

This work is required as an insect-proof and dust-proof countermeasure for the sensor exterior.

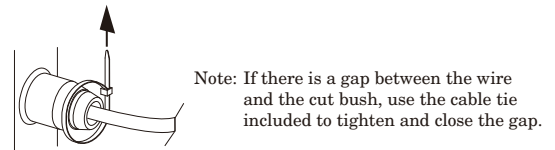

- 4**
- Refer to section **5 WIRING METHOD** to connect the wiring. Refer to section **6 OPTICAL AXIS ADJUSTMENT** to adjust the optical axis.

- 5**
- Attach the cover to the sensor body, and fix it in place using the cover fixing screws.
  - Note: Cut the knockout at the top using nippers or equivalent tools as and when needed.
  - Attach bird stoppers to the cover as and when needed.

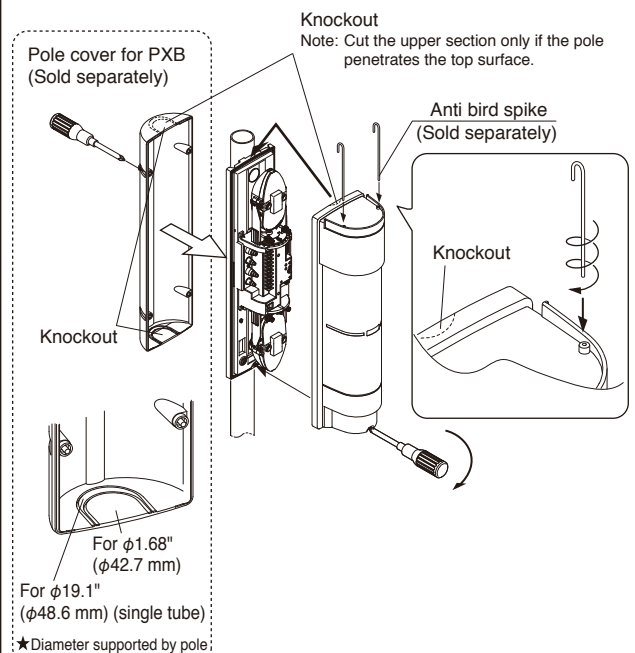

# 5 WIRING METHOD

## 5-1 POSITION AND RATING OF TERMINALS

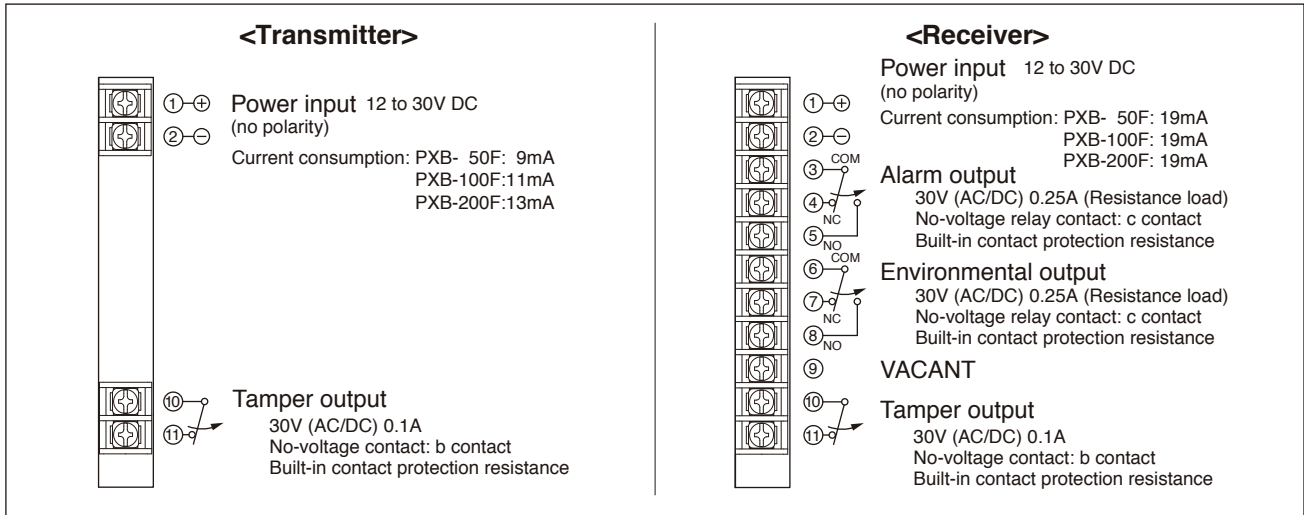

## 5-2 WIRING DISTANCE BETWEEN SENSOR AND POWER SUPPLY

Part No. Size of electrical cable used	PXB-50F		PXB-100F		PXB-200F	
	12V DC	24V DC	12V DC	24V DC	12V DC	24V DC
AWG 20 (Dia,0.8mm)	Up to 2,700ft. ( 823m)	Up to 19,000ft. ( 5,790m)	Up to 2,500ft. ( 750m)	Up to 17,000ft. ( 5,200m)	Up to 2,300ft. ( 700m)	Up to 16,000ft. ( 4,880m)
AWG 18 (Dia,1.0mm)	Up to 4,200ft. (1,280m)	Up to 29,500ft. ( 8,990m)	Up to 3,800ft. (1,160m)	Up to 27,500ft. ( 8,380m)	Up to 3,700ft. (1,130m)	Up to 25,000ft. ( 7,500m)
AWG 17 (Dia,1.1mm)	Up to 5,100ft. (1,550m)	Up to 36,000ft. (11,000m)	Up to 4,800ft. (1,460m)	Up to 33,000ft. (10,000m)	Up to 4,500ft. (1,370m)	Up to 31,000ft. ( 9,500m)
AWG 16 (Dia,1.25mm)	Up to 6,600ft. (2,000m)	Up to 46,000ft. (14,000m)	Up to 6,200ft. (1,890m)	Up to 43,000ft. (13,100m)	Up to 5,800ft. (1,770m)	Up to 40,000ft. (12,000m)
AWG 15 (Dia,1.4mm)	Up to 8,300ft. (2,500m)	Up to 58,000ft. (17,700m)	Up to 7,800ft. (2,380m)	Up to 53,000ft. (16,000m)	Up to 7,300ft. (2,350m)	Up to 51,000ft. (15,500m)
AWG 14 (Dia,1.6mm)	Up to 10,500ft. (3,200m)	Up to 76,000ft. (23,200m)	Up to 10,000ft. (3,000m)	Up to 71,000ft. (21,600m)	Up to 9,500ft. (2,900m)	Up to 66,000ft. (20,000m)

● When 2 or more units are connected, the wiring distance is calculated as follows: [Above value/number of units]

## 5-3 WIRING DISTRIBUTION DIAGRAM (WIRING DIAGRAM)

### ● Basic connections

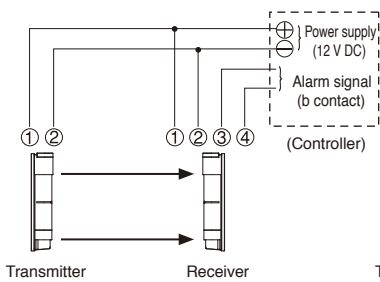

### ● When multiple sensor units are connected to the same circuit

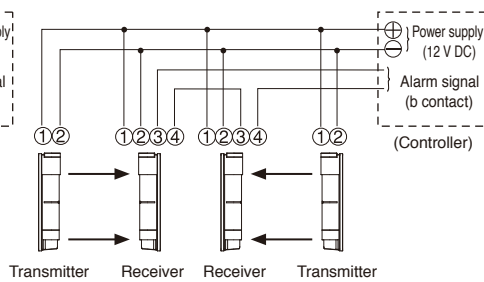

### ● When multiple sensor units are connected to separate circuits

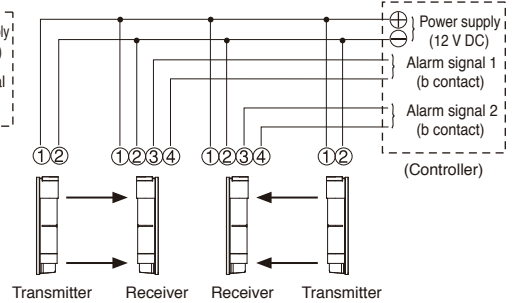

### ● For environmental output, tamper output

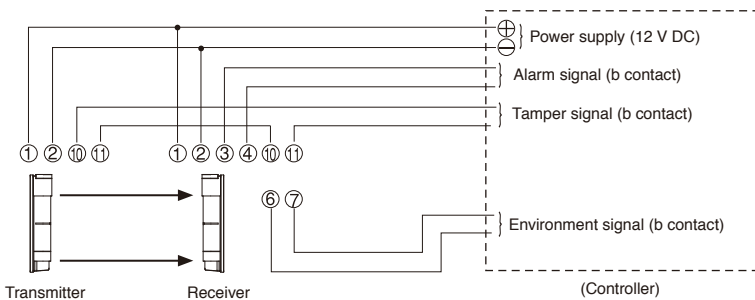

### [Precautions for Installation]

- (1) Signal output for the upper and lower levels of the receiver cannot be output separately.
- (2) For outdoor wiring installation, carry out pipe laying work whenever possible.
- (3) Never use overhead wiring.



# 6 OPTICAL AXIS ADJUSTMENT

By aligning the optical axis correctly, a protection line with sufficient margin of sensitivity can be created, reducing the occurrence of malfunction. Always adjust the optical axis on both upper and lower levels.

## 6-1 NAMES AND FUNCTIONS OF OPTICAL AXIS ADJUSTMENT PARTS

### ● Names of the Optical Unit

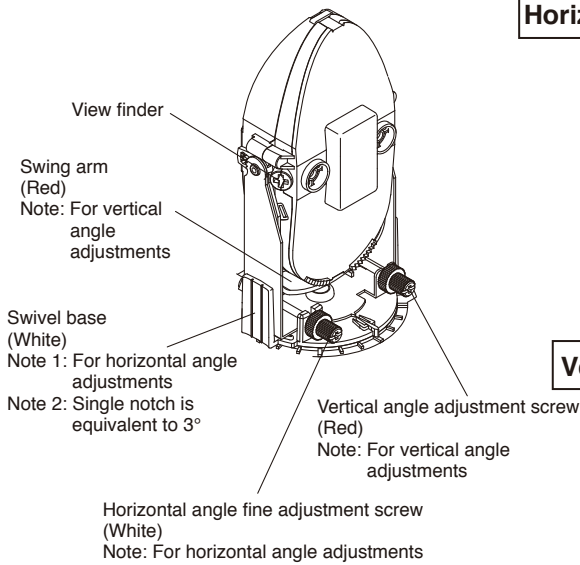

### ● Reflector Section Horizontal/Vertical Angle Adjustment Method

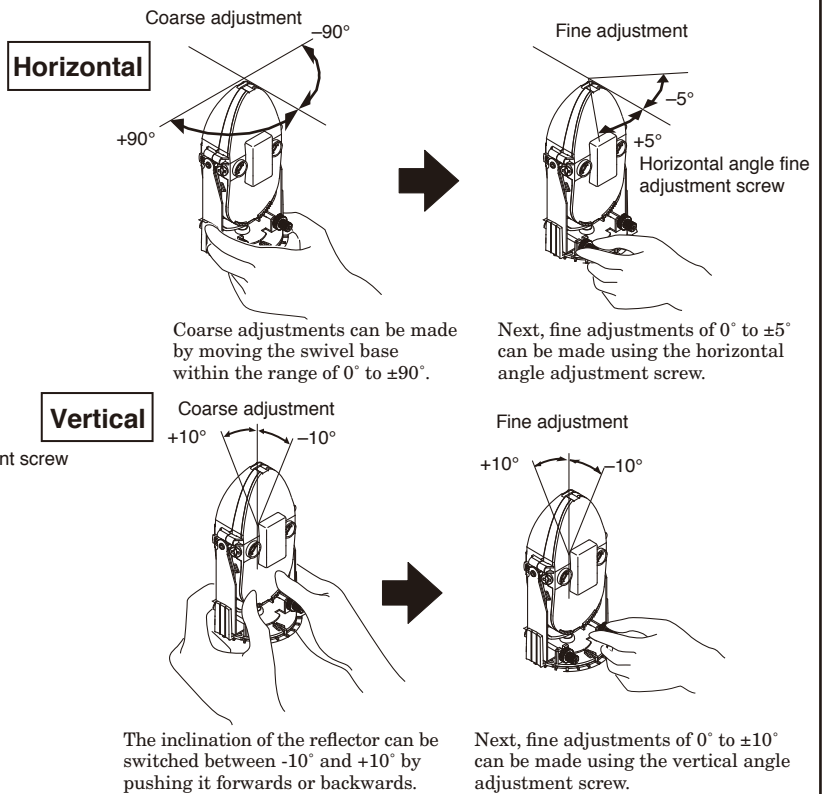

### ● Double Ring Alignment Mechanism Visible from the view finder

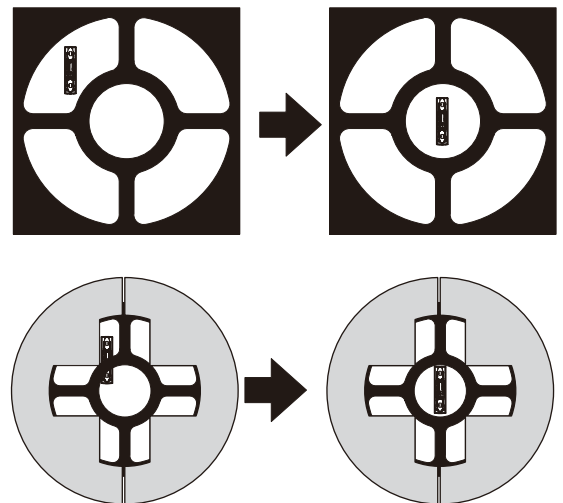
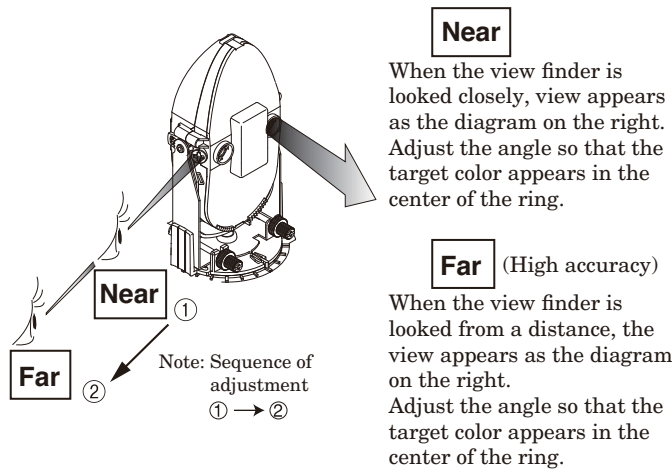

### ● Names of the Operation Section

Note: This section describes the name and function of each part used during optical axis adjustment.

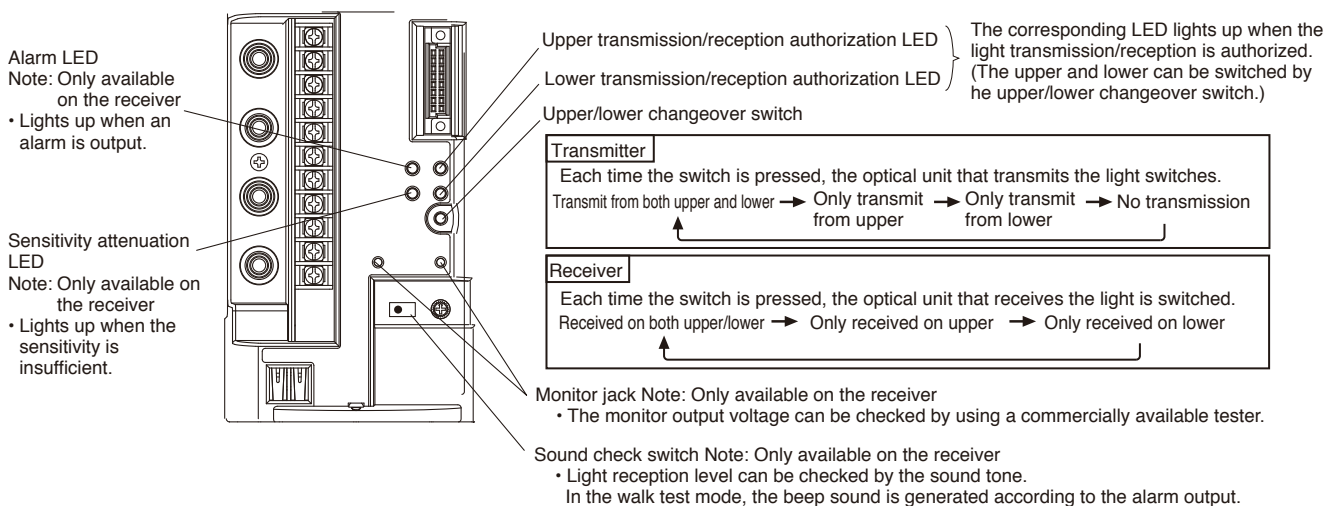

## 6-2 OPTICAL AXIS ADJUSTMENT USING THE ALIGNMENT MECHANISM

- 1** Move the swivel base and swing arm so that the opposite device is roughly aligned with the view finder.

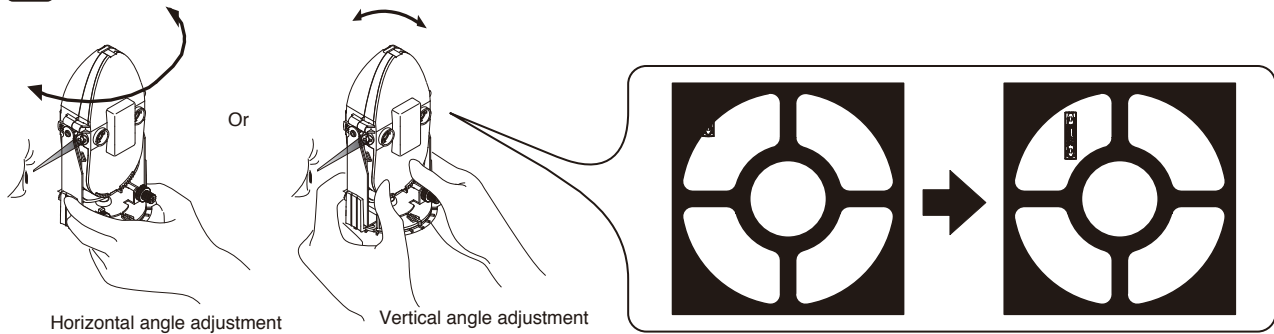

- 2** Look closely through the view finder, and adjust the position so that the sensor of the opposite device is visible at the center of the ring using the horizontal and vertical angle fine adjustment screws.

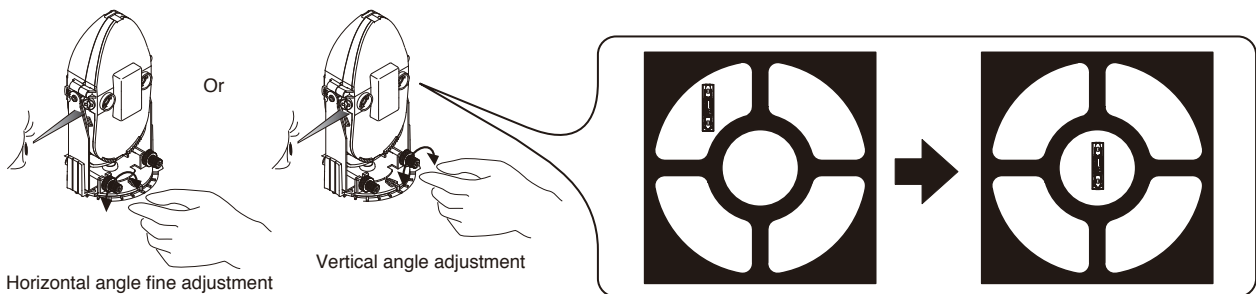

- 3** Look through the view finder from a distance, and readjust so that the sensor of the opposite device is visible at the center of the ring using the horizontal and vertical angle fine adjustment screws.

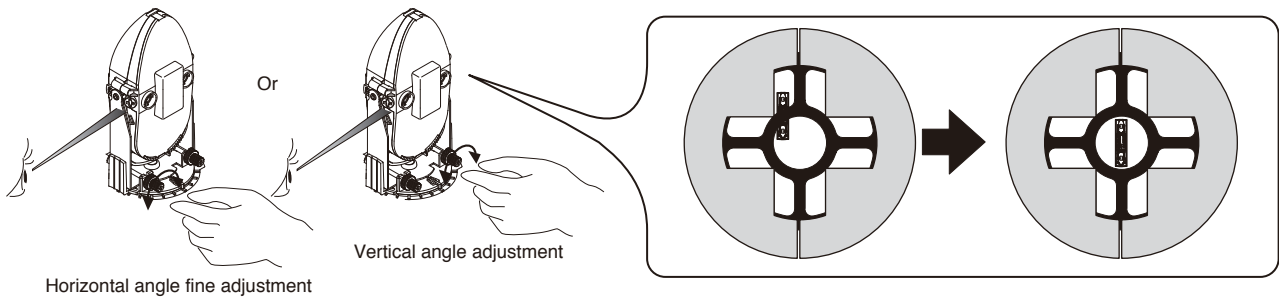

- 4** Turn on the power to the transmitter and receiver, check that the LEDs of both the transmitter and receiver are lit.

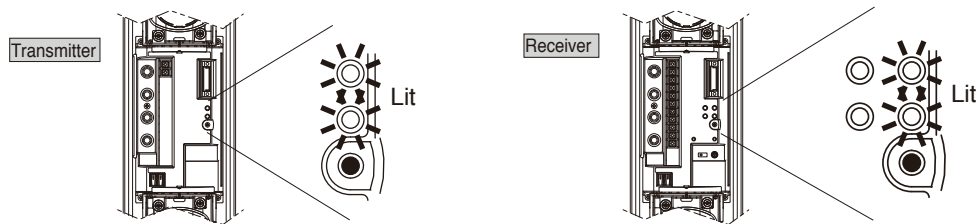

- If the LED of the receiver indicates as follows, take an appropriate measure according to the following description.

		Description of the Display	Remedy
Receiver		(1) The light enters the receiver, but the light reception level is insufficient (The optical axis is misaligned)	(1) Go to step <b>5</b> and fine adjust the optical axis
		(1) Different channels are set for the transmitter and receiver (2) The photoelectric beams are interfered	(1) Set the same channel for the transmitter and receiver (2) Change to a channel that is not influenced by other factors
		(1) The light does not enter the receiver at all (The optical axis is not adjusted correctly)	Go back to step <b>1</b> and adjust the optical axis again

- 5 To improve accuracy of optical axis  
 Perform the procedure of “Optical Axis Adjustment Using the Sound Check”, “Optical Axis Fine Adjustment Using the Monitor Output Voltage”, or “Optical Axis Fine Adjustment Using the Alignment Wireless Checker”.

### Optical Axis Fine Adjustment Using the Sound Check

- The sound check function indicates the light reception level by using high and low pitch tones.
- The sound check function is only installed on the receiver.

#### <<Caution>>

First, check only the transmission on the upper level and reception on the upper level, and then check only the transmission on the lower level and reception on the lower level.

(When the light can be received on both the upper and lower levels, the beep sound at the total light reception level of the upper and lower levels are generated.)

1. Turn the sound check switch on the receiver to the ON position.  
 When the optical axis is roughly aligned, the beep sound can be heard.  
 The optical axis is greatly misaligned if no sound can be heard.

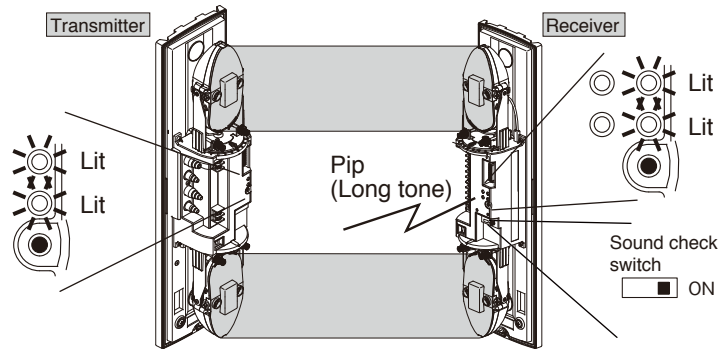
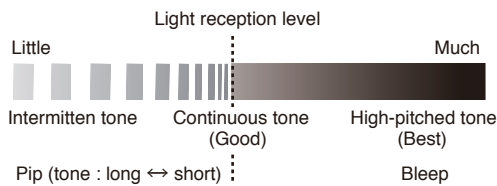

2. Fine adjust the upper level optical axis.

- (1) Press the upper/lower changeover switch on the transmitter to select [Only transmit from upper].
- (2) Press the upper/lower changeover switch on the receiver to select [Reception authorization on upper only].
- (3) Turn the adjustment screw to fine adjust until the tone reaches the highest pitch.  
 (Adjust both the transmitter and receiver.)

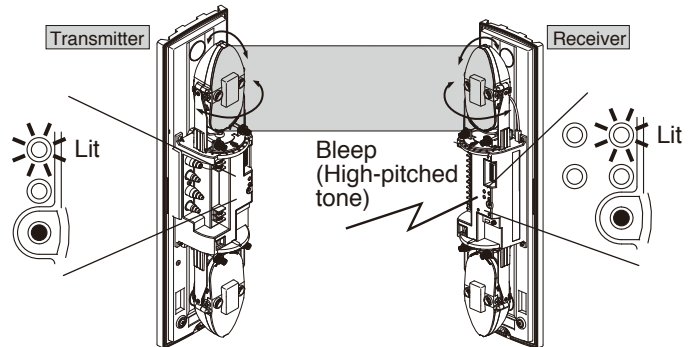

3. Fine adjust the lower level optical axis.

- (1) Press the upper/lower changeover switch on the transmitter to select [Only transmit from lower].
- (2) Press the upper/lower changeover switch on the receiver to select [Reception authorization on lower only].
- (3) Turn the adjustment screw to fine adjust until the tone reaches the highest pitch.  
 (Adjust both the transmitter and receiver.)

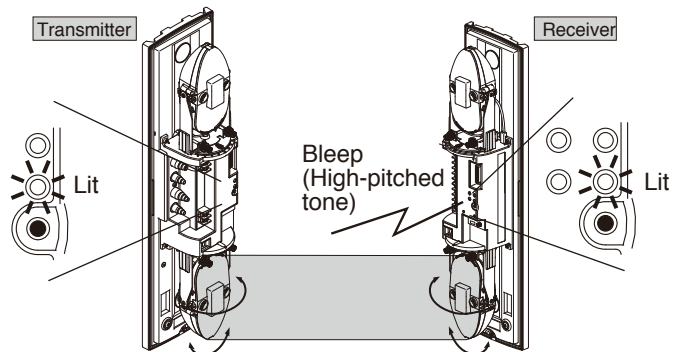

4. Check if the light from another transmitter enters the receiver.

- (1) Press the upper/lower changeover switch on the transmitter to select [No transmission].
- (2) Press the upper/lower changeover switch on the receiver to select [Reception authorized for both upper and lower].
- (3) Check that the alarm LED lights up when the receiver outputs an alarm signal, and that the sensitivity attenuation LED also lights up.

- If no alarm is activated or the sensitivity attenuation LED is not lit  
 When using multi-level protection, there may be some effects of other photoelectric beam sensors. In such case, readjust the other photoelectric beam sensors to reduce the effects to the minimum possible.

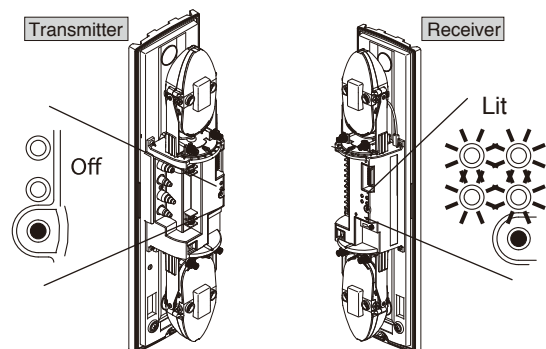

## Optical Axis Fine Adjustment Using the Monitor Output Voltage

- Accurate adjustments of the optical axis can be achieved by checking the light reception level value using the voltage of the monitor output.

### <<Caution>>

First, check only the transmission on the upper level and reception on the upper level, and then check only the transmission on the lower level and reception on the lower level.

(The values are not displayed correctly when the light can be received for both the upper and lower levels.)

See the following table for the monitor output voltage.

Monitor Output Voltage	Light Sensitivity
More than 2.5 V DC	Best
2.3 to 2.5V DC	Good
Less than 2.3V DC	Poor, re-adjust

1. Insert a commercially available tester into the monitor jack on the receiver.

### <<Caution>>

The monitor jack is polarized.

Check the polarity of the tester pin before inserting it.  
Use a tester with an internal resistance of over 100 kΩ.

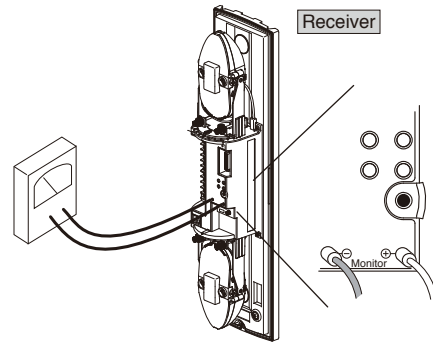

2. Fine adjust the upper level optical axis.

- (1) Press the upper/lower changeover switch on the transmitter to select [Only transmit from upper].
- (2) Press the upper/lower changeover switch on the receiver to select [Reception authorization on upper only].
- (3) Turn the adjustment screw to fine adjust until the monitor output voltage reaches the highest value.  
(Adjust both the transmitter and receiver.)

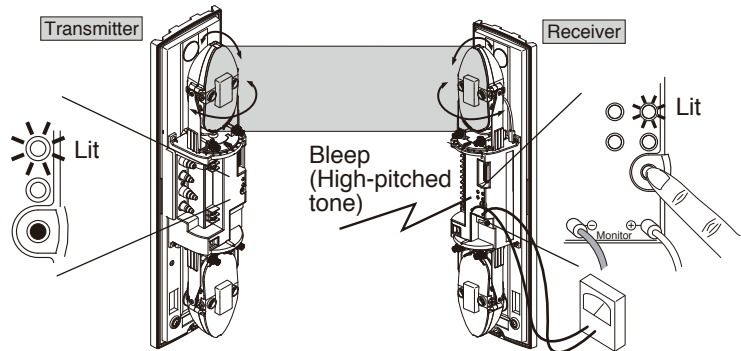

3. Fine adjust the lower level optical axis.

- (1) Press the upper/lower changeover switch on the transmitter to select [Only transmit from lower].
- (2) Press the upper/lower changeover switch on the receiver to select [Reception authorization on lower only].
- (3) Turn the adjustment screw to fine adjust until the monitor output voltage reaches the highest value.  
(Adjust both the transmitter and receiver.)

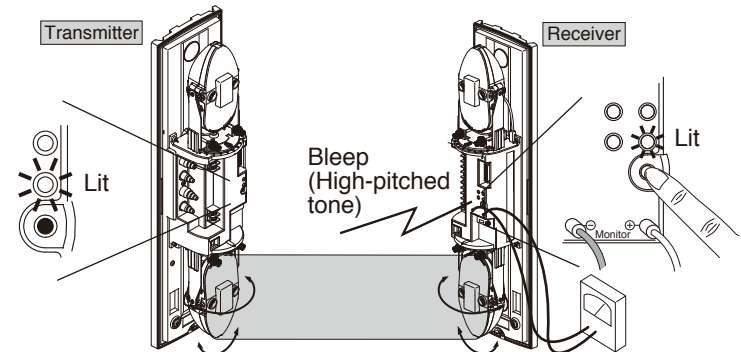

4. Check if the light from another transmitter enters the receiver.

- (1) Press the upper/lower changeover switch on the transmitter to select [No transmission].
- (2) Press the upper/lower changeover switch on the receiver to select [Reception authorized for both upper and lower].
- (3) Check that the alarm LED lights up when the receiver outputs an alarm signal, and that the sensitivity attenuation LED also lights up. Also check the monitor output voltage.

- If no alarm is activated or the sensitivity attenuation LED is not lit

When using multi-level protection, the monitor output voltage may become close to "1 V" due to effects of other photoelectric beam sensors. In such case, readjust the other photoelectric beam sensors to reduce the effects to the minimum possible.

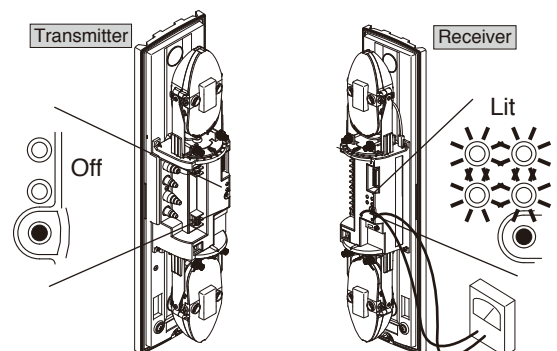

## Optical Axis Fine Adjustment Using the Alignment Wireless Checker: ER-02 (Sold Separately)

- Accurate adjustments of the optical axis can be achieved by checking the light reception level value using the voltage of the monitor output.
- As the light reception level value can also be checked using the voltage on the transmitter, more accurate adjustments of the optical axis can be achieved.

Using the alignment wireless checker enables easy and accurate beam alignment.

Providing sufficient margin of sensitivity increases resistance to the dense fog, snow, and heavy rain, which makes it possible to construct a highly reliable intrusion alarm system.

Note: For detailed operation procedure of the alignment wireless checker, refer to the instruction manual for the alignment wireless checker ER-02.

# 7 OPERATION CHECK

Be sure to perform an operation check after the optical axis adjustment.

- 1 When the optical axis adjustment is completed, attach the cover.
- 2 Obstruct the sensor beams near the sensor or the center of the detection line and check that an alarm can be output correctly.
  - If the sound check switch is set to ON, the walk test mode is activated for five minutes after the cover is closed. The beep sounds is generated in synchronization with the alarm output. The alarm LED lights up according to the alarm output.

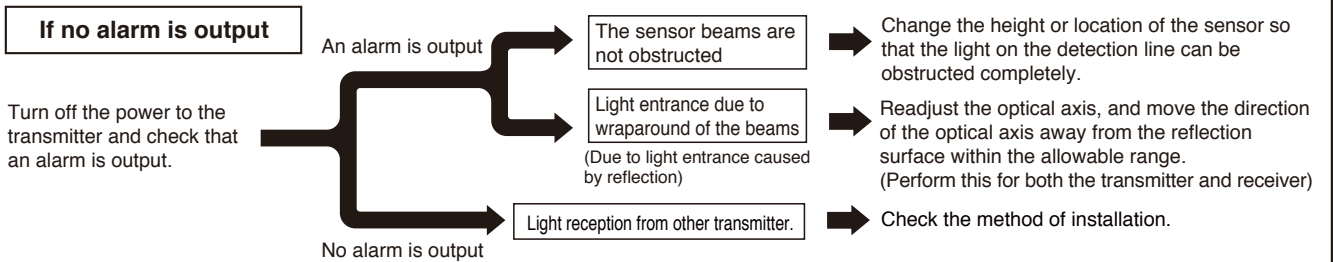
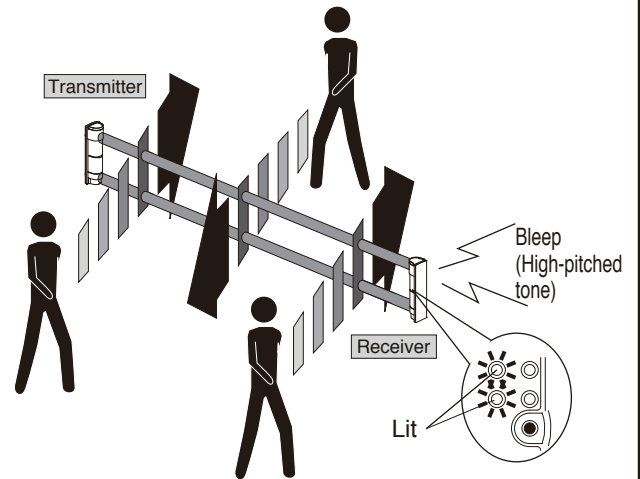

# 8 EXPLANATION OF FUNCTIONS

This section describes the detailed information of the functions that appear in this instruction manual. Set each function according to the description below.

This device features the functions that must be set for operating the device, as well as those that are necessary for adjustment procedures. Perform setting and adjustment by checking the following table.

Whether to set on transmitter or receiver	Setting item	Setting
Receiver only	Sound check	<input type="checkbox"/> ON <input type="checkbox"/> OFF
	Response time	<input type="checkbox"/> 0.05 secs (Standard) <input type="checkbox"/> 0.3 secs <input type="checkbox"/> 0.7 secs <input type="checkbox"/> Other

## 8-1 SOUND CHECK FUNCTION

Note: Only installed on the receiver

- You can be notified of the light reception status or current alarm operation on the receiver by the sound of alarms.

OFF  ON   
 Sound check switch  
 (Factory setting: OFF)

Item	Operation (status)	Other settings
Light reception level	Light reception level can be checked by the sound tone. (The tone pitch becomes higher as the light reception level increases.)	While the receiver cover is removed.
Walk test mode	The beep sound is generated according to the alarm output. (Activated for approximately 5 minutes after auto gain lock)	

## 8-2 RESPONSE TIME ADJUSTMENT FUNCTION

Note: Only installed on the receiver

- The detectable interruption time can be adjusted (Refer to the diagram below to adjust the response time)

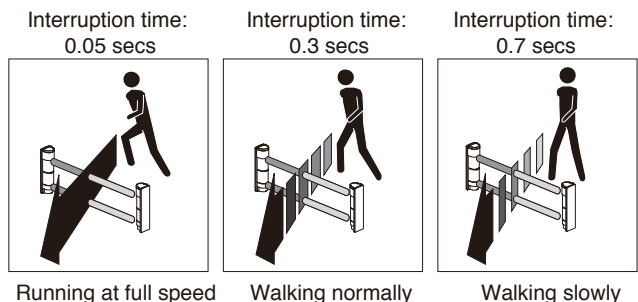
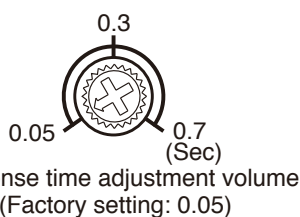

**<<Caution>>**

- (1) If the interruption time is shorter than the response time, the obstructing object is not detected.
- (2) In areas where there are large objects that could be blown and obstruct the optical axis (e.g., birds, a lot of paper, and cardboard), set the response time slightly slower by taking the installation condition into consideration. (However, if the response time is too slow, the units may not detect an intruder.)



### 8-3 UPPER/LOWER CHANGEOVER FUNCTION

Note: Installed on the transmitter and the receiver

- This function allows you to switch the optical unit to transmit/receive the light by pressing the upper/lower changeover switch.
- Note: The sensors switch as shown in the diagram below when the upper/lower changeover switch is pressed.

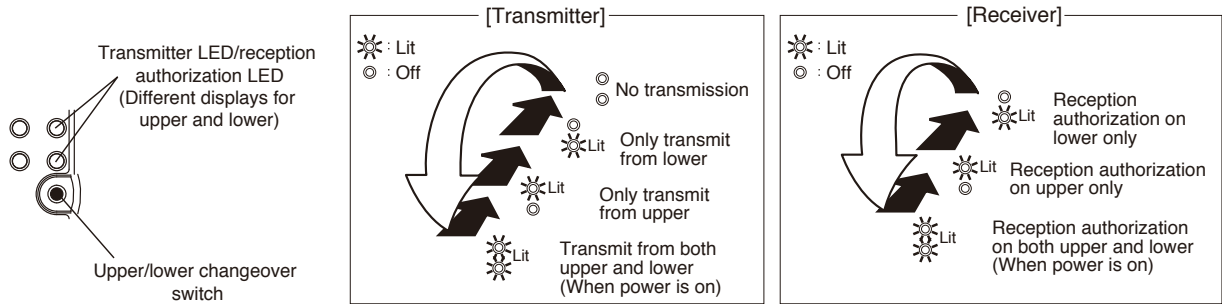

### 8-4 LIGHT SENSITIVITY SIGNAL FUNCTION

Note: Only installed on the receiver

- The LED lights up when the light reception level is considered to be insufficient in order to notify the operator of that an inspection is necessary.

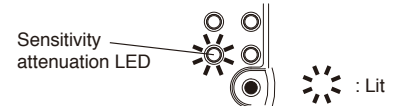

### 8-5 EXTERNAL ENVIRONMENT DIAGNOSTIC FUNCTION

Note: Only installed on the receiver

- The light reception level falls below the specified level under adverse environmental conditions such as dense fog or heavy rain. This function issues an environmental output if such conditions are maintained.

Note: The environmental output continues until the light reception level for both the upper and lower beams recovers to the specified level (for 5 seconds at the shortest).

### 8-6 ALIGNMENT WIRELESS CHECKER CONNECTION FUNCTION

Note: Installed on the transmitter and the receiver

- Using the alignment wireless checker that is sold separately enables easy and accurate optical axis adjustment. Providing sufficient margin of sensitivity increases the resistance to the dense fog, snow, and heavy rain, which makes it possible to construct a highly reliable intrusion alert system.

## 9 TROUBLESHOOTING

- Check the device by referring to the table below. If you cannot restore the device to a normal condition after the check, contact the place of purchase or TAKEX.

Status	Cause	Remedy
Transmitter LED does not light (cover is open)	(1) Power is not on (2) Poor wiring or breaking of wire, short (3) Transmitter is set to [Do not transmit]	(1) Connect the power source (2) Check again (3) Press the upper/lower changeover switch
Alarm LED does not light even if the photoelectric beam is obstructed	(1) Power is not on (2) Poor wiring or breaking of wire, short (3) Photoelectric beam is reflected by some object and entering the receiver (4) Four levels are not obstructed simultaneously (5) Sensor beam is obstructed for less time than the detection response time setting in the receiver	(1) Connect the power source (2) Check again (3) Remove the reflecting object, or change the installation location or optical axis direction (4) Obstruct four levels simultaneously (5) Shorten the detection response time
Alarm LED does not go out (Alarm output does not stop)	(1) Optical axis (alignment) is not aligned correctly (2) There is an obstruction between the transmitter and receiver (3) Transmitter/receiver cover or reflection section is dirty	(1) Perform angle adjustment again (2) Remove the object (3) Clean using a soft cloth
Continually activated	(1) Poor wiring connection (2) Change of supply voltage (3) Obstruction between transmitter and receiver (objects such as branches that move with the wind) (4) The wiring of the transmitter/receiver is located nearby a power line (5) Unstable sensor installation (6) Transmitter/receiver cover or reflection section is dirty (7) Improper alignment of optical axis (8) A large bird or cat may obstruct the beams	(1) Check again (2) Stabilize the supply voltage (3) Remove the object  (4) Change the wiring route  (5) Fix in a stable location (6) Clean using a soft cloth (7) Perform optical axis adjustment again, (8) Set the response time to be slightly longer (however, this is not possible if there is a possibility that an intruder could run through at top speed)

#### Daily Inspections

- To clean the device, use a soft, wet cloth and then wipe off any water drops. If the device is particularly dirty, dip the soft cloth in water that includes a weak neutral detergent. Wipe the device gently with the cloth, then wipe off any detergent that remains. Do not use substances such as thinner or benzene. (The plastic parts may deform, discolor or change their properties.)
- Perform operation checks on a regular weekly basis.

# 10 SPECIFICATIONS

Model	PXB-50F	PXB-100F	PXB-200F
Detection system	Near infrared pulsed beam interruption system (TR-RE 4 beam simultaneous interruption)		
Infrared beam	Double modulation pulsed beam by LED		
Protection distance	Outdoor 165' (50 m) or less	Outdoor 330' (100 m) or less	Outdoor 660' (200 m) or less
Max. arrival distance	1650' (500 m)	3300' (1000 m)	6600' (2000 m)
Response time	0.05 sec. to 0.7 sec. (Variable at pot)		
Power supply	12 to 30V DC (Non-polarity)		
Current consumption	28 mA or less	30 mA or less	32 mA or less
Alarm output	Dry contact relay output form C Contact action : Interruption time (Min.2sec.) Contact capacity : 30V (AC/DC) 0.25A (resistive load) Protective resistor		
Environmental output	Dry contact relay output form C Action : Activated when weather condition gets worse Contact capacity : 30V (AC/DC) 0.25A (resistive load) Protective resistor		
Tamper output	Dry contact relay (N.C.) Action : Activated when cover is detached Contact capacity : 30V (AC/DC) 0.1A (resistive load) Protective resistor		
Alarm LED	Red LED (Receiver) ON : when an alarm is initiated		
Attenuation LED	Red LED (Receiver) ON : when beam is attenuated		
Ambient temperature range	-31°F to +151°F (-35°C to +66°C)		
Beam adjustment	Horizontal: ±90°, Vertical: ±20°		
Functions	Tone indicator, Environmental module, Monitor jack, Tamper Response time adjustment, Upper/Lower beam switch, Wireless checker Automatic gain control		
Mounting positions	Outdoor, Indoor		
IP rating	65		
Wiring	Terminals		
Weight	Transmitter : 52.5oz (1500g) Receiver : 54.3oz (1550g)		
Appearance	Resin (wine red)		

# 11 EXTERNAL DIMENSIONS Unit: inch (mm)

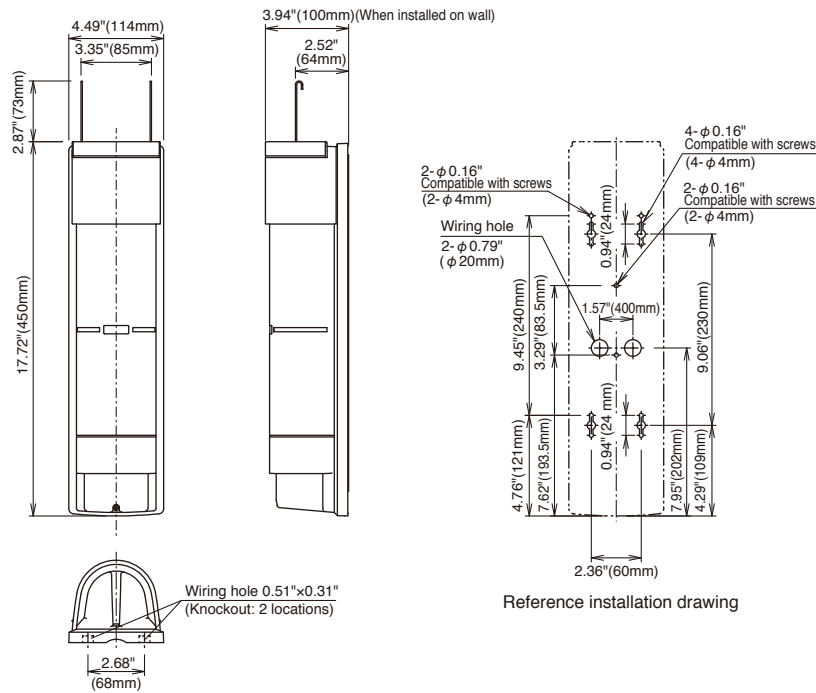

● Pole installation dimensional drawing

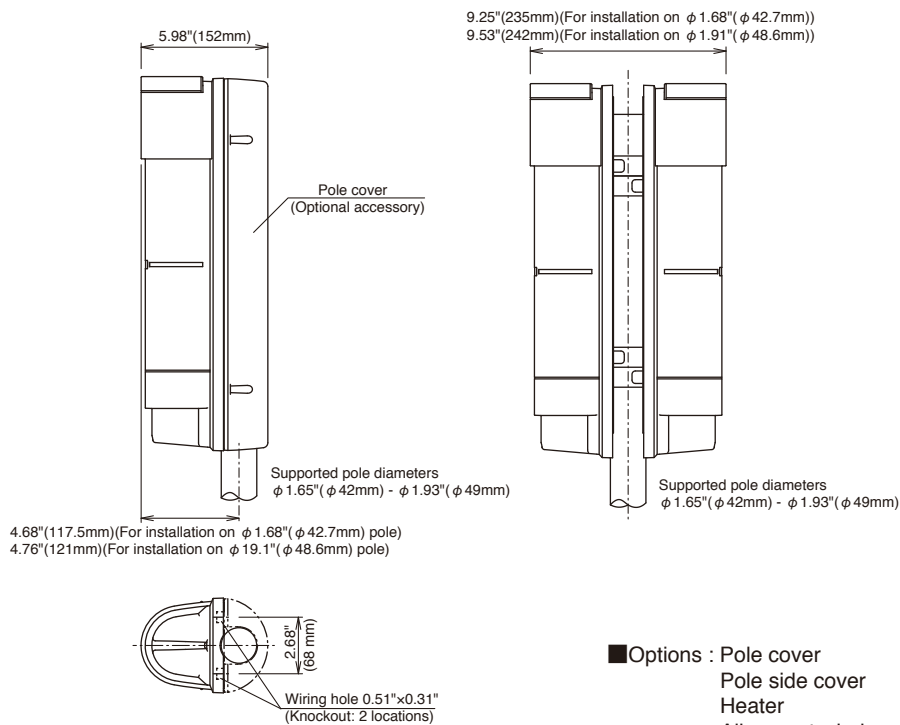

- Options : Pole cover : BP-50X
- Pole side cover : BS-50XP
- Heater : HTF-24A
- Alignment wireless checker : ER-02

## Limited Warranty :

TAKEX products are warranted to be free from defects in material and workmanship for 12 months from original date of shipment. Our warranty does not cover damage or failure caused by natural disasters, abuse, misuse, abnormal usage, faulty installation, improper maintenance or any repairs other than those provided by TAKEX. All implied warranties with respect to TAKEX, including implied warranties for merchantability and implied warranties for fitness, are limited in duration to 12 months from original date of shipment. During the Warranty Period, TAKEX will repair or replace, at its sole option, free of charge, any defective parts returned prepaid. Please provide the model number of the products, original date of shipment and nature of difficulty being experienced. There will be charges rendered for product repairs made after our Warranty Period has expired.



In Japan  
**Takenaka Engineering Co., Ltd.**  
 83-1, Gojo-sotokan, Higashino,  
 Yamashina-ku, Kyoto 607-8156, Japan  
 Tel : 81-75-501-6651  
 Fax : 81-75-593-3816  
<http://www.takex-eng.co.jp/>

In the U.S.  
**Takex America Inc.**  
 151, San Zeno WAY  
 Sunnyvale, CA 94086, USA  
 Tel : 408-747-0100  
 Fax : 408-734-1100  
<http://www.takex.com>

In Australia  
**Takex America Inc.**  
 4/15 Howleys Road, Notting Hill,  
 VIC, 3168  
 Tel : +61 (03) 9544-2477  
 Fax : +61 (03) 9543-2342

In the U.K.  
**Takex Europe Ltd.**  
 Aviary Court, Wade Road,  
 Basingstoke, Hampshire. RG24 8PE, U.K.  
 Tel : (+44) 01256-475555  
 Fax : (+44) 01256-466268  
<http://www.takex.com>