

TAKENAKA

Color Registration Mark Sensor

Model: MU10N

1 Description:

The Takenaka registration color mark sensor is designed to detect a wide range of colored marks including red, black, brown, dark blue, and blue.

The Takenaka model MU10N employs a solid-state pulse modulation, visible (green), visible energy source and has detection circuitry which sensitive only to a proper modulated light source.

Because this switch operate on the Takenaka pulsed LED principle it is unaffected by particularly incandescent or sunlight.

The model MU10N contains a pulse LED light source, photo-detection circuitry, amplifier, and output circuit in common housing.

The sensitivity adjustment is provided on the sensor for optimizing the signal level for the object being sensed.

The standard unit is housed in poly-carbonate.

When using the standard output options, N series control unit are available.

The standard output unit IP1N, IP1F are a SPDT relay rated at 5A 250V AC noninductive, and voltage output

2 Application:

This technique is useful when intended for detection of registration marks on the edge of web material.

Typical Applications

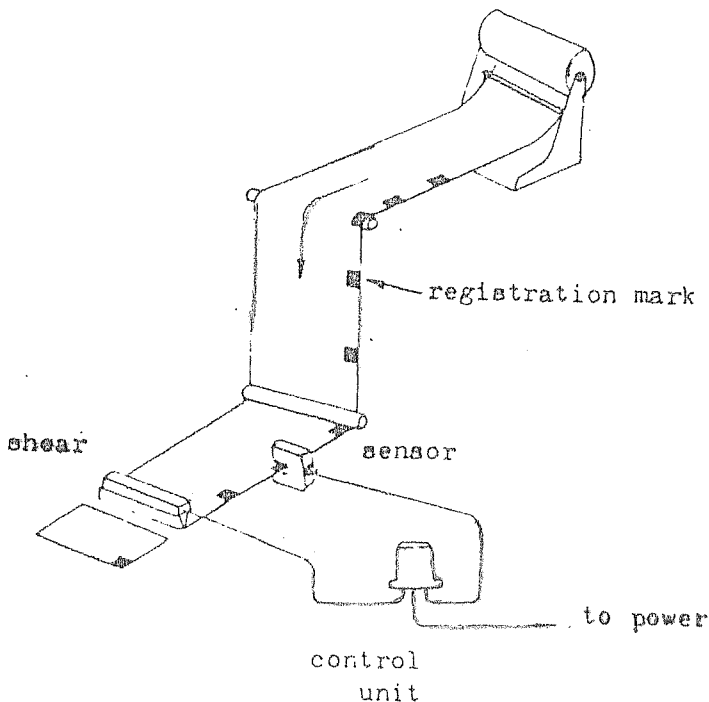

Photoelectrically controlled cutting from registration mark

Light interrupted by registration marks, when labels are printed, photoelectrically actuates electrically operated shear.

3 Specifications:

| | |
|---------------------|---|
| model | MU10N |
| range | 10mm (fixed) |
| radiant source | LED (light emitting diode) green |
| sensing cell | Phototransistor |
| control output | open collector and voltage output |
| rating | current sink 100mA, voltage 30V |
| operational voltage | DC 12V -10% ~ 24V +10% |
| current dissipation | 30mA DC 12V 35mA DC 24V |
| response time | 5msec for voltage output |
| ambient temperature | -10°C to +50°C |
| vibration-proof | loop amplification 1.5mm, 2000 CPM each one hour to X,Y,Z directions |
| connections | cable lead out, 0.3sqX cable furnished cable 3m. |
| weight | 220g |

4 Functional description:

The light source pulse oscillator supplies high current pulses to the LED at rate determined by the oscillator frequency in the sensor. The LED emits intense pulses of visible (green) energy in response to these pulses.

The sensing cell generates a signal corresponding to the incoming energy level.

The signal from the sensing cell is amplified, and fed to threshold circuitry.

The signal from the threshold circuitry is fed to the output circuit.

5 Installation:

The MU10N mark sensor must be securely mounted on firm, stable surfaces or supports.

Mounting which is subject to shifting or vibration may cause intermittent operation.

6 Wiring:

When using the IP series control unit

Remove approximately 30mm of outside covering from the cable, and strip the wire approximately 9mm. Remove the mounting screw, insert cable through the cable clamp. Wire connection is made without lugs by inserting the bare wire under the terminal clamping plate and tightening the screw.

Sensor wiring to IP series control unit

The sensor cable should be connected to terminal strip points marked NO 8 (WHT wire), NO 9 (RED wire), and NO 10 (BLK wire).

GRN. NON CONECT

In case of the relay output

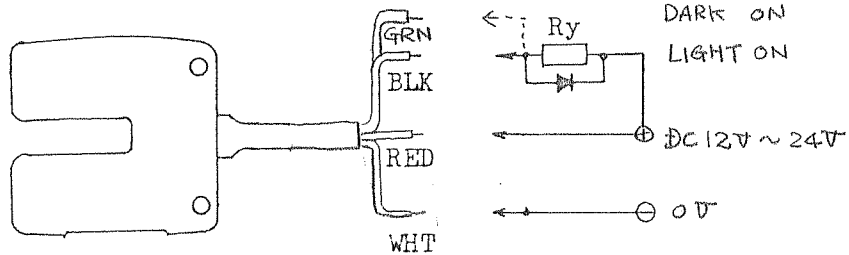

Note

Insert diode for absorbing surge across the relay coil.

In case of the voltage output

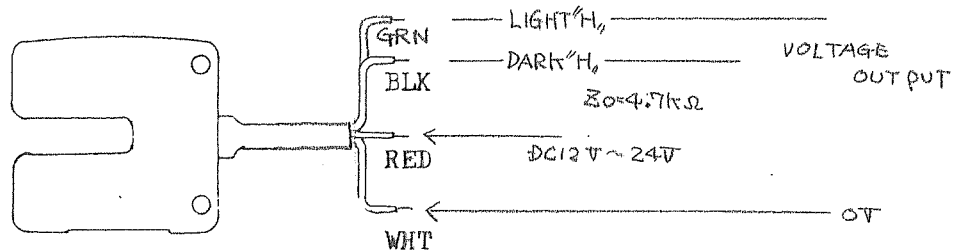

7 Sensitivity adjustment:

Making the sensitivity adjustment

Rotate the sensitivity adjustment screw on top of the sensor, using a small screwdriver, such as a jeweler's screwdriver.

Insert the object to be detected into gap (10mm) of the light source and receiver.

- ① Turn the sensitivity adjustment screw on top of the sensor clockwise.
- ② With power on, projects the beam to the background of the object. Then, Be sure that operating indicator lamp goes on. Next, projects the beam to the registration mark on the surface of the object. Then, Be sure that operating indicator lamp goes off. And vice versa.
- ③ If no operating indicator lamp goes off, rotate the sensitivity adjustment screw on top of the sensor counterclockwise until the operating indicator lamp goes off.
- ④ In this sensitivity adjustment point, Projects the beam to the background of the object. Then, operating indicator lamp goes on. And further rotate the sensitivity adjustment screw on top of the sensor counterclockwise until the operating indicator lamp goes off.
- ⑤ Finally, turn the sensitivity adjustment screw back counterclockwise again to a point midway between those you found in steps ③ and ④. This is the best setting of the sensitivity adjustment.

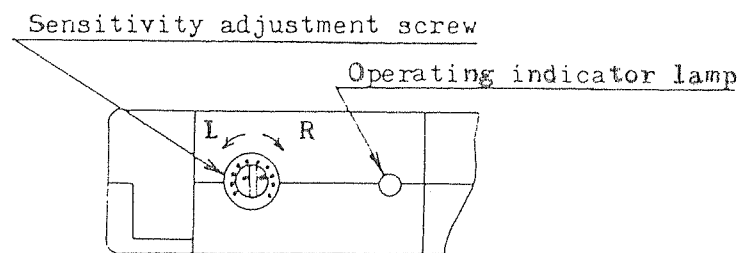

Sensor top view

8 Color selection chart

| Object | Film sheet with a transmission ratio of 10% ~ 100% | | | | | |
|--------|--|-----|-----|---------|-----|-----|
| Model | RED | BLK | BRN | NVY BLU | GRN | BLU |
| MU10N | ○ | ○ | ○ | ○ | △ | ○ |
| MU10NR | — | ○ | △ | ○ | ○ | ○ |

○ : Detection is possible.

△ : Detection may be possible according to the color shade.

— : Not suitable for use.

Remarks: RED--Red, BLK--Black, BRN--Brown, NVY BLU--Navy blue, GRN--Green
BLU--Blue,

Note

This color selection chart should be used with the understanding that it is only a guide and not a guarantee that all color combinations can be detected.

The only way to make certain a particular color combination can be detected is to actually test the sensor.

9 Maintenance & Inspection:

The only maintenance required on the Takenaka model MU10N sensor is to periodically clean the lens, to assure that the mounting hardware is tight and that it has not changed position relative to the object being detected.

| | | | |
|-----------------|----------------|------------|------------|
| 変更 REVISIONS | 記事 CONTENTS | 日付 DATE | 名前 NAME |
| △ | | | |

A

B

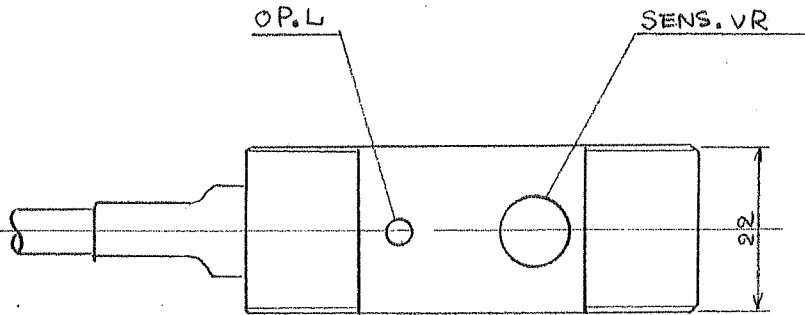

C

D

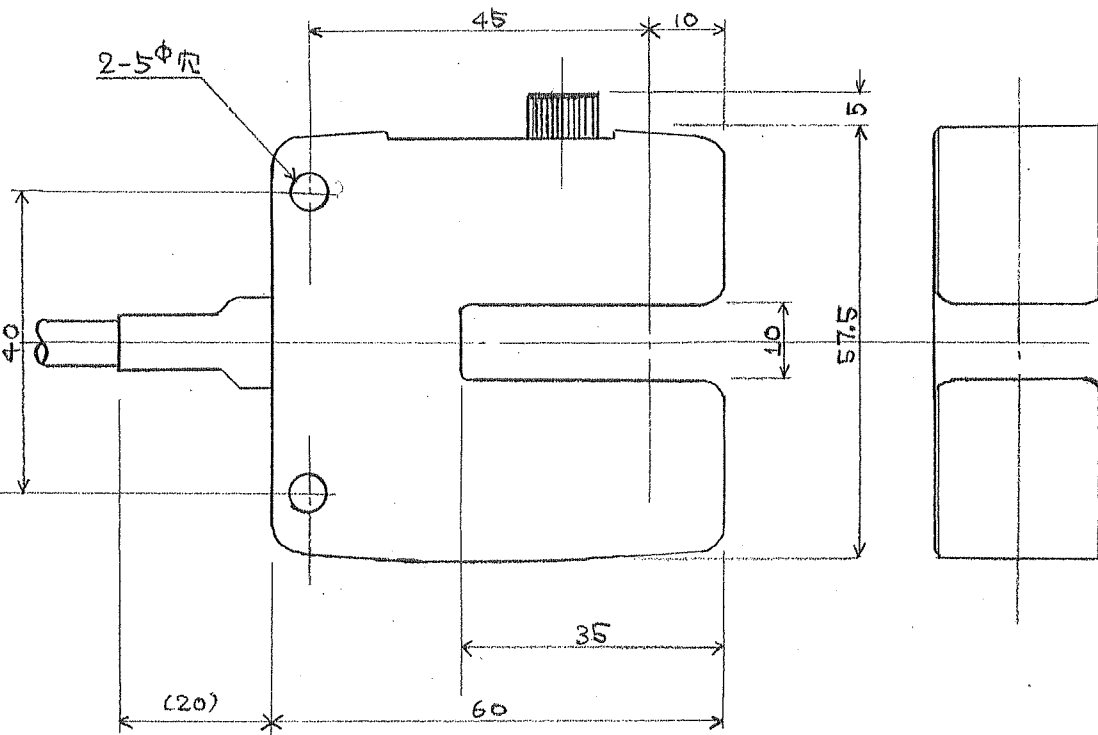

| | | | | |
|---|------------------------------|--------------------|-------------------|-------------------------------------|
| NO. | 品名 DESCRIPTION | 材質 MATERIAL | 規格 STANDARD | 仕上 FINISH |
| 第三角法 3RD ANGLE PROJECTION | 尺度 SCALE 1/1 | 日付 DATE '85.7.3.12 | | 名称 TITLE DIMENSIONS |
| | | 単位 UNIT mm | | |
| 承認 APPROVED BY | 検図 CHECKED BY | 製図 DRAWN BY | 設計 DESIGNED BY | 図面番号 DRAWING NO. DG-16464 |
| <i>Shoichi Mitsutake</i> | <i>Shoichi Mitsutake</i> | | <i>H. Kichiji</i> | △ △ △ |
| TAKENAKA ELECTRONIC INDUSTRIAL CO., LTD. | | | | |