

SSC-T800 series

Sequential Array Scanning
Light Curtain Sensors



- Fine object detection with Sequential Array Scanning
- With a robust metal case!
- Five kinds of beam intervals, which you can select according to use!
 - Small objects and flat tape-like objects detected
 - Convenient simplified wiring requiring no clock (synchronization) line
 - Compact and flat (14.5 mm)
 - Water resistance compliant with IP 67

Type

Detection method	Detecting distance	Beam interval	No. of Optical axes	Detecting width	Set model No.	
					NPN output	PNP output
Through beam	100-500mm	5.55mm	10	50mm	SSC-T801	SSC-T801PN
	0.4-1.2m				SSC-T802	SSC-T802PN
	0.5-2m	12.5mm	5		SSC-T804	SSC-T804PN
	100-500mm				SSC-T805	SSC-T805PN
	150-800mm	16.6mm	10	150mm	SSC-T850	SSC-T850PN
		11mm	10	100mm	SSC-T810	SSC-T810PN
					6	SSC-T815
			10			SSC-T830
					20mm	6
		0.5-2.5m	11mm		10	100mm
20mm	6		SSC-T835		SSC-T835PN	

The detecting distance is the range which you can set for the sensor. The sensor can detect an object even in the immediate area of the sensor.

Sequential Array Scanning

SSC-T800 makes a sequential scan of a two dimensional array formed by each transmitter and the whole set of corresponding receivers.

This method of scanning creates a high-density detection net between the transmitter and the receiver. Thin pipe, tape or name cards that pass through conventional light curtains can be reliably detected.

The figure on the right shows a model with six light axes. The number of light axes depends on the model.

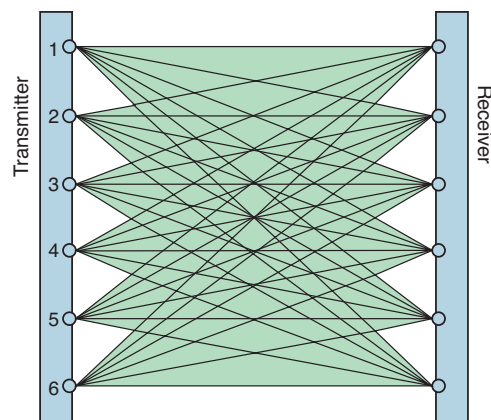

SSC-T800

Rating/Performance/Specification

Set model No.	NPN	SSC-T801	SSC-T802	SSC-T804	SSC-T805	SSC-T850	SSC-T810	SSC-T815	SSC-T830	SSC-T835	
	PNP	SSC-T801PN	SSC-T802PN	SSC-T804PN	SSC-T805PN	SSC-T850PN	SSC-T810PN	SSC-T815PN	SSC-T830PN	SSC-T835PN	
Detection method	Through beam										
Detecting distance	100-500mm	0.4-1.2m	0.5-2m	100-500mm	150-800mm			0.5-2.5m			
Detection object	Opaque φ6mm or more	Opaque φ8mm or more	Opaque φ15mm or more	Opaque φ12.5mm or more	Opaque φ17mm or more	Opaque φ11mm or more	Opaque φ20mm or more	Opaque φ13mm or more	Opaque φ22mm or more	Opaque φ22mm or more	
No. of light axes	10		5		10		6	10	6		
Detecting width	50mm				150mm	100mm					
Optical axis interval	5.55mm		12.5mm		16.6mm	11mm	20mm	11mm	20mm		
Power supply	12 - 24V DC ±10% / Ripple 10% or less										
Current consumption	Transmitter	50mA or less		50mA or less		80mA or less		80mA or less	80mA or less	80mA or less	
	Receiver	100mA or less *		65mA or less *		110mA or less *		70mA or less *	110mA or less *	70mA or less *	
Output mode	NPN	NPN open collector Rating: sink current 100 mA (30 VDC or less)									
	PNP	PNP open collector Rating: source current 100mA (30 VDC or less)									
Operation mode	Activated when light beams of all axes are received (deactivated when light beam of any axis is blocked)*1										
Response time	Light blocking :5ms or less Light reception 8ms or less		Light blocking :3ms or less Light reception 4ms or less		Light blocking :5ms or less Light reception 8ms or less						
Light source (wavelength)	Infrared LED (870nm)										
Indicator	Transmitter: Power indicator (Green LED) Receiver: Power indicator (Green LED) / Operation indicator (Orange LED)										
Short circuit protection	Provided										
Material	Case body: Aluminum / Caps at ends: glass fiber filled PBT / Froth cover : Acrylic										
Connection	Attached cable (dia.4 mm) 3 m Cable: 0.3 mm ² x 2 cores, gray (transmitter) or 0.3 mm ² x 3 cores, black (receiver)										
Weight	Approx. 130 g (transmitter/receiver)				Approx. 190 g (transmitter/receiver)	Approx. 130 g (transmitter/receiver)					
Accessory	Operation manual (Note) Mounting brackets are not provided										
Notes	*The receiver current consumption shown is for 12 VDC. When the voltage is 24 VDC, the consumption is reduced to about 60%. *1 "-D" types, or models deactivated when light beams of all axes are received, are also available.										

The detecting distance is the range which you can set for the sensor. The sensor can detect an object even in the immediate area of the sensor.

Environmental Specification

Ambient light	5,000lx or less
Ambient temperature	-10 - +55°C (non-freezing)
Ambient humidity	35-85%RH (non-condensing)
Protective structure	IP67
Vibration	10-55 Hz / 1.5 mm double amplitude / 2 hours each in 3 directions
Shock	500 m/s ² / Twice each in 3 directions
Dielectric withstanding	500 VAC for 1 minute
Insulation resistance	500 VDC, 20 MΩ or higher.

Applicable power supply unit

PS Series
High capacity of 200 mA at 12 VDC

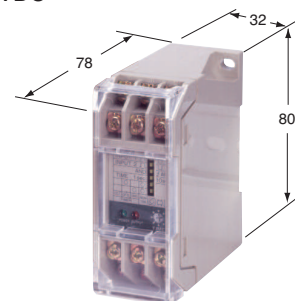

(General-purpose type) PS3N
PS3N-SR
(Multifunctional type) PS3F
PS3F-SR

SSC-T800

Input/Output Circuit and Connection

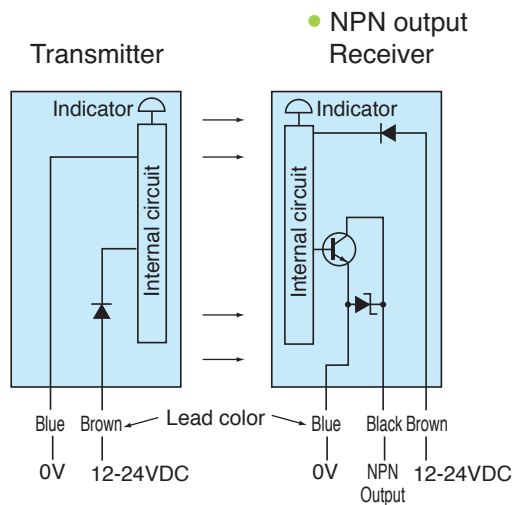

Operation time chart

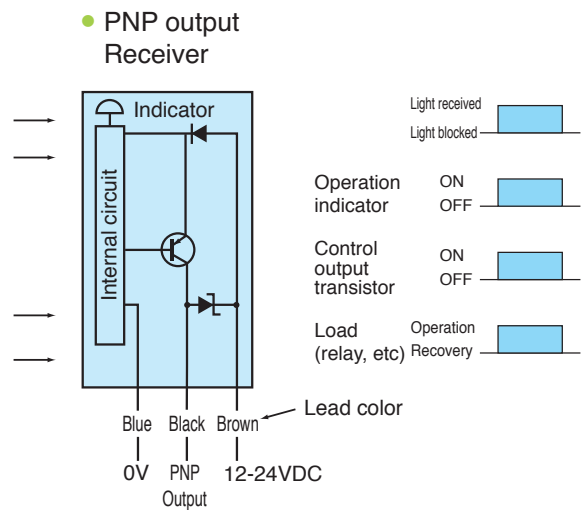

The output transistor turns off when load short circuits or overload occurs. Check the load and turn the power back on.

Setting

Install the transmitter and receiver face-to-face.

Swivel the transmitter and receiver vertically and horizontally to install them at the center of the area in which the operation indicator (orange LED) is illuminated for the individual direction.

The tightening torque for installing the sensor (with M4 screws) should be up to 0.6 N·m.

- Displacement in the A direction may be up to $\pm 30\text{mm}$. Displacement in the B direction should be within $\pm 10\text{mm}$.
- If the transmitter and receiver are too closely installed to each other or light axes are misaligned, the output may be unstable. When the light axes are aligned, the operation returns to normal.

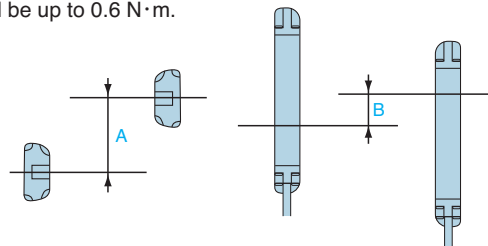

- Any reflecting object (wall, floor, machine, etc.) within the detecting range between the transmitter and receiver may allow the light beam to go around the detection object which is supposed to block the light, and reach the receiver. Choose the installation location carefully.

Any glossy object such as a coated surface in the surrounding area must be at least 100mm or 150mm away from the optional axes when the distance setting is less than 1m or more than 1m respectively.

- Avoid interference when installing sensor adjacently. (See Response Curves : Lateral Gap / Longitudinal Gap)

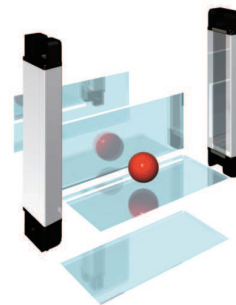

For Correct Use



- Be sure to follow the instructions in the operation manual provided for correct use of the product.
- This sensor cannot be used as a power press safety device or other safety device to prevent death or injury that requires conformity to domestic or overseas standards or certification concerning protection of human body. Use for such purposes may lead to death or serious injury.
- This sensor is designed to detect an object passing over a certain point or line.
- When using this sensor for safety purposes except those mentioned above, ensure safe operation of the system as a whole including detection and control function.

Performance Curves (Typical)

Response Curves : Lateral Gap / Longitudinal Gap

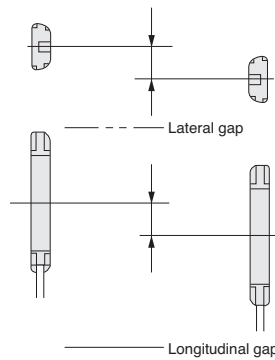
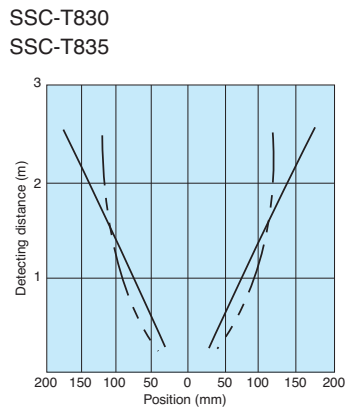
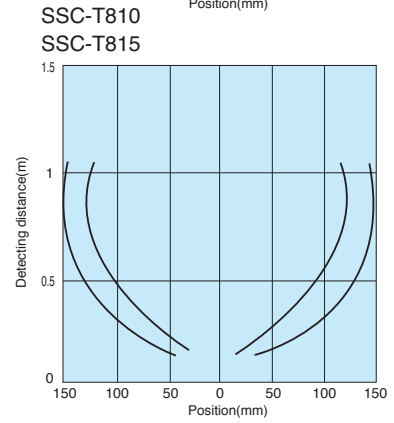
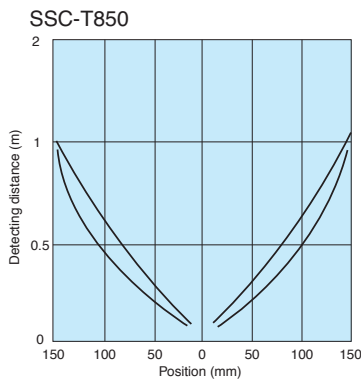
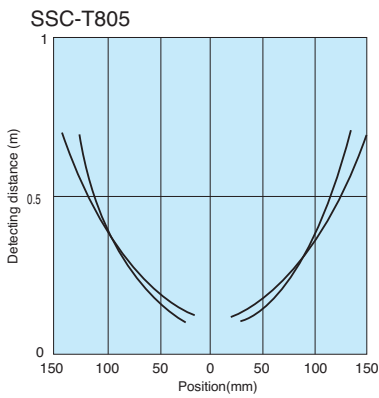
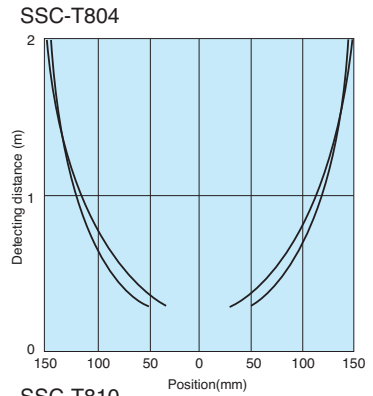
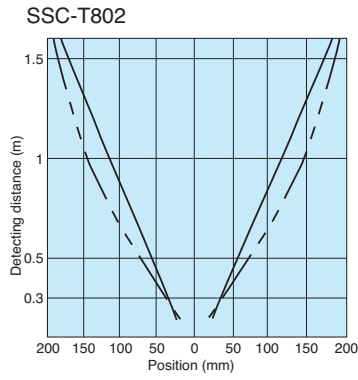
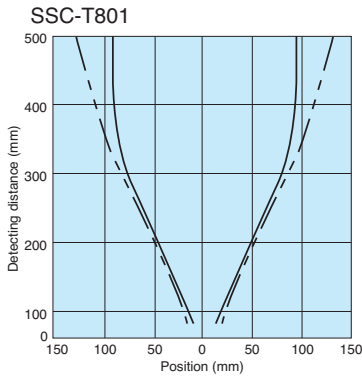

SSC-T800

Performance Curves (Typical)

Response Curves : Tilt Angle

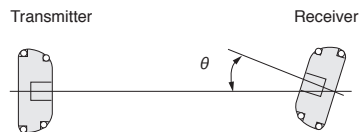
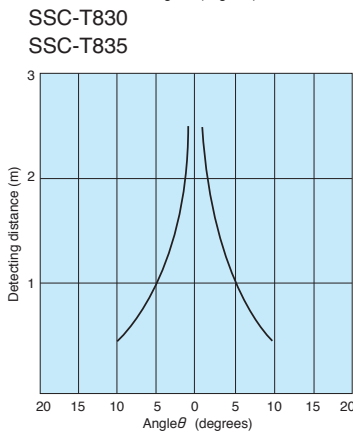
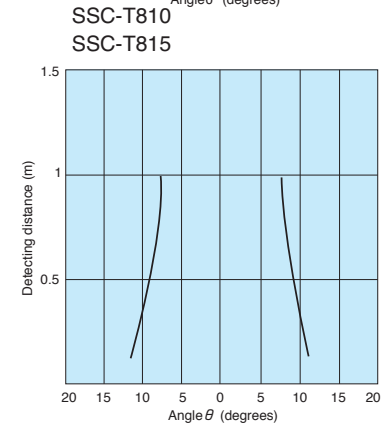
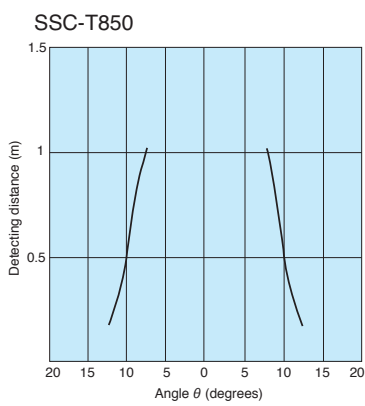
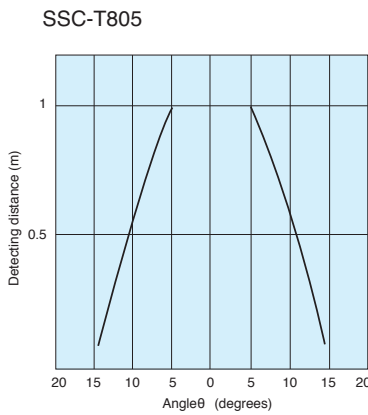
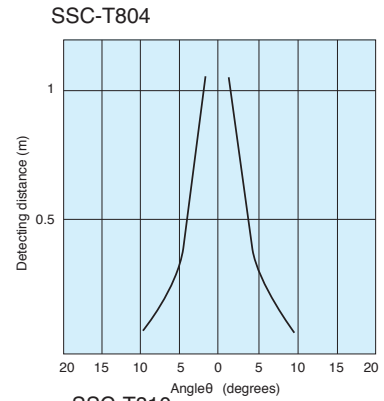
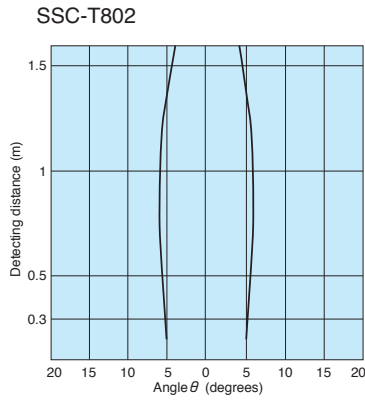
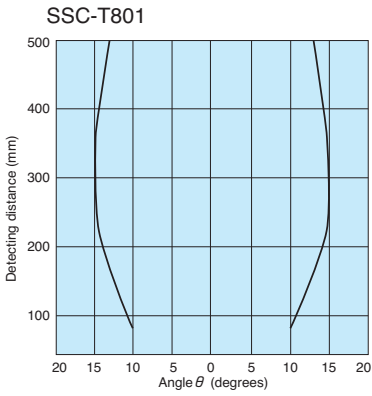

Performance Curves (Typical)

Response Curves : Minimum Detection Object

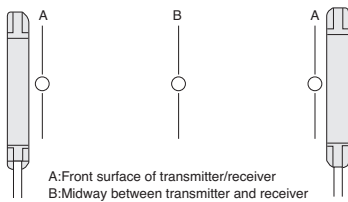
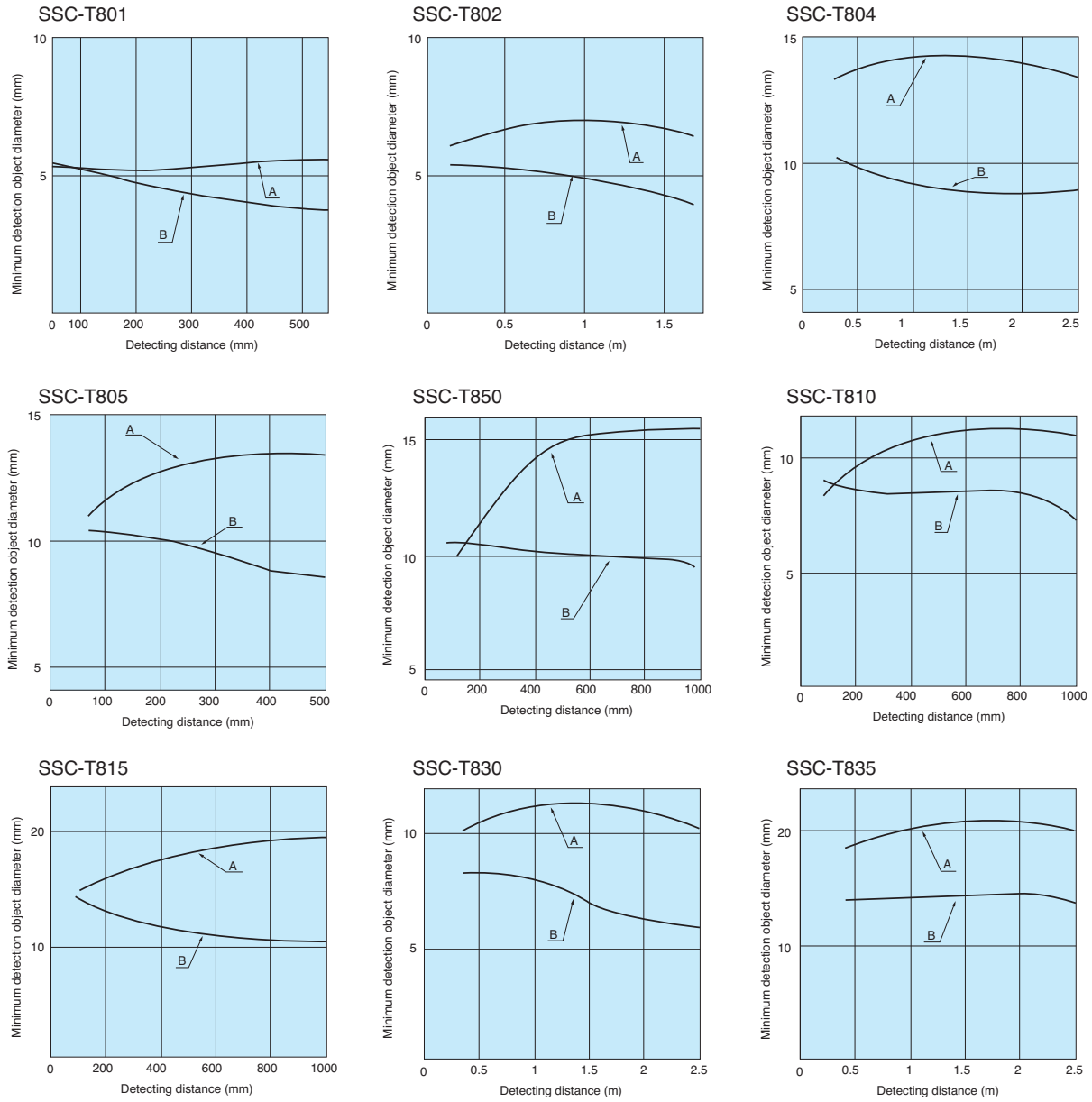

SSC-T800

Dimensions (in mm)

(When installing the main unit of the sensor, the tightening torque has to be 0.6N · m or less.)

SSC-T801 SSC-T804
SSC-T802 SSC-T805

CAD

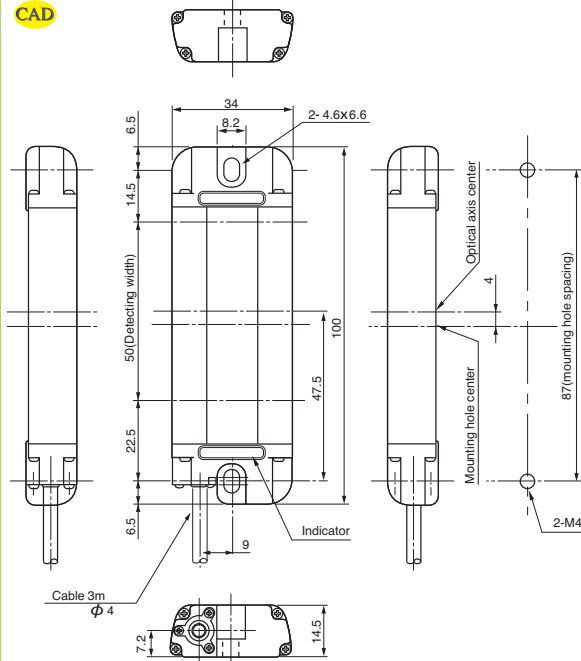

SSC-T850

CAD

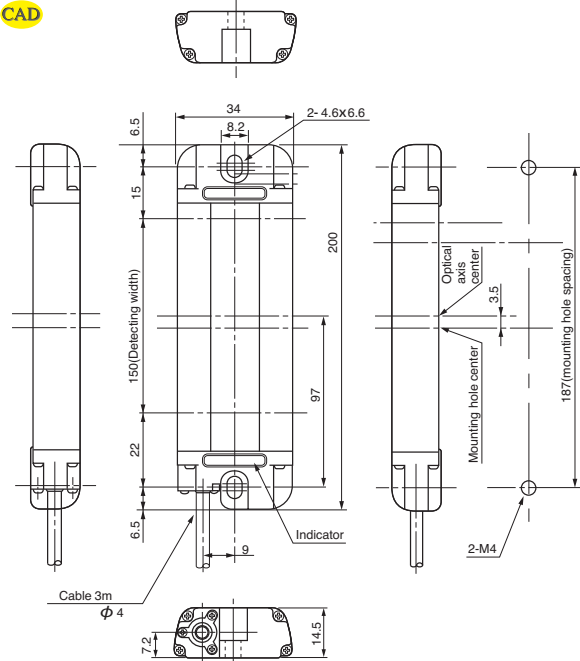

SSC-T810
SSC-T830

CAD

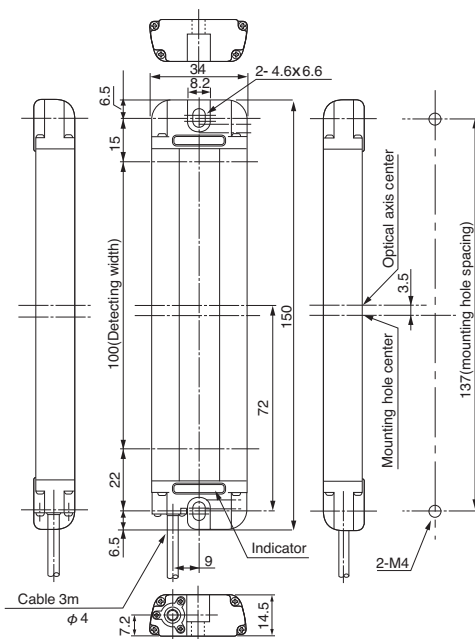

SSC-T815
SSC-T835

CAD

