

TAKEX FLASHLIGHT SIREN BEAM

PBS-15T

Instruction Manual

We appreciate your purchase of a TAKEX photoelectric beam. This sensor will provide long term, dependable service when properly installed. Please read this Instruction Manual carefully for correct and effective use.

Please Note : This sensor is designed to detect intrusion and to initiate an alarm ; it is not a burglary-preventing device.

TAKEX is not responsible for damage, injury or losses caused by accident, theft, Acts of God (including inductive surge by lightning), abuse, misuse, abnormal usage, faulty installation or improper maintenance.

1 PRODUCT DESCRIPTION

PBS-15T is an infrared beam sensor which consists of a transmitter and a receiver with built-in flash light and siren. The unit is designed to intimidate intruders by initiating high-intensity LED flash lights or electronic sound siren when detection. The upper and lower beams are ideally located with a gap of 9.4"(24cm) and AND gated in order to reduce nuisance alarms caused by birds, little animals or falling leaves.

2 PARTS DESCRIPTION

Receiver

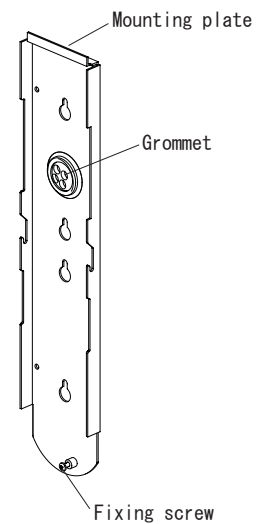
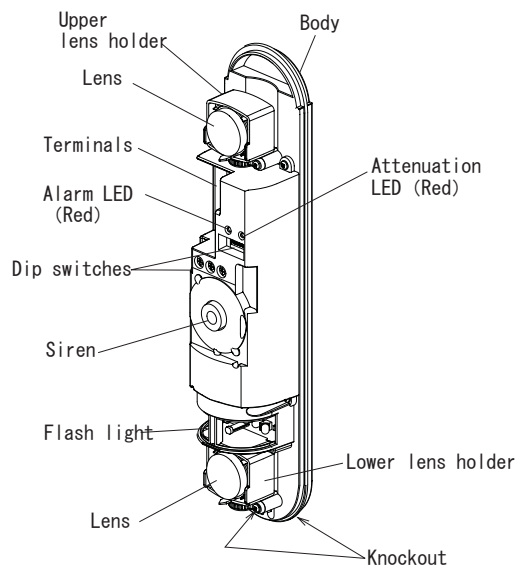
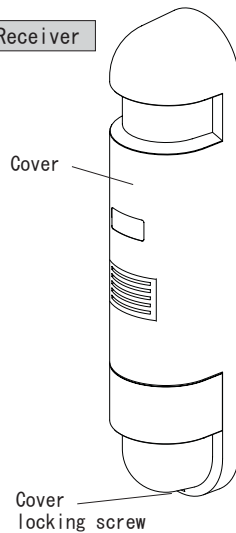

Transmitter

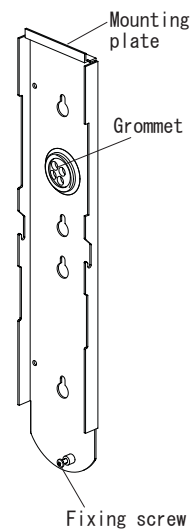
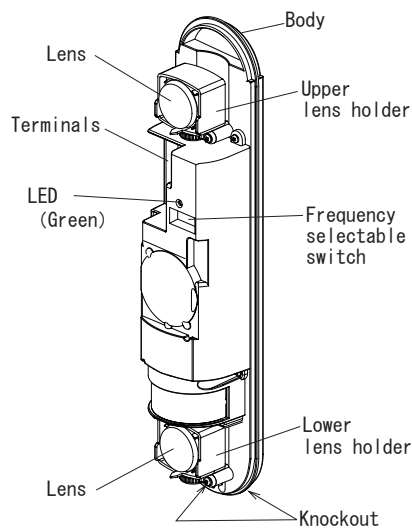
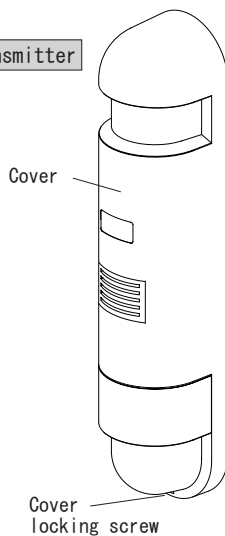

Accessories

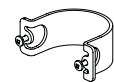

U bracket: 2 pcs

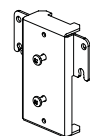

Pole mounting plate: 2 pcs



Tapping screw: 4 pcs
(ϕ 4 x 20)

3 PRECAUTIONS

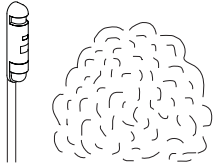

● Remove all obstructions (trees etc.) between transmitter and receiver.

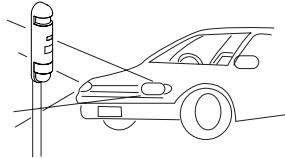

● Avoid strong light from the sun, automobile headlights etc. directly going on to transmitter / receiver. When strong light stays in optical axis for a long time, it does not cause malfunction but will affect the product life.

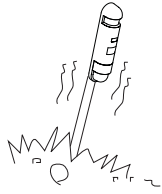

● Do not install the unit on unsteady surfaces.

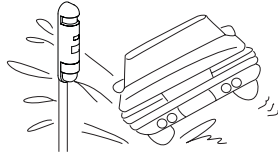

● Do not install the unit on places where it may be splashed by dirty water or direct sea spray.

● Ensure that the transmitter and the receiver are installed vertically at the same height as the beams cannot be adjusted vertically.

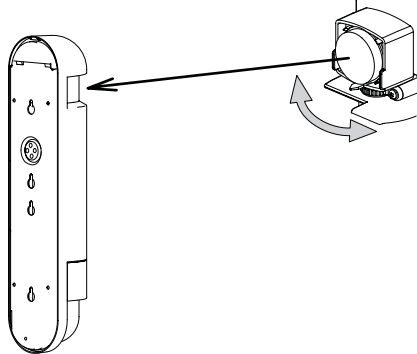

- When installing the unit on wall or pole, install it at a height between 70cm and 90cm from the ground to catch human pattern. When using it for a fence protection, install it at a little higher place than the height of the fence so that it can detect human beings when they try to climb over the fence.
- When installing the unit on a fence or wall, make sure that the unit is installed approx. 15cm away from the top surface of the fence or wall to avoid false alarm caused by birds or cats.

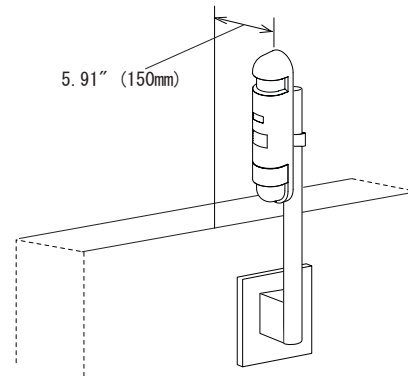
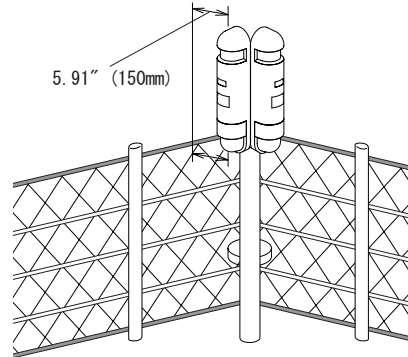

● Wide beam expansion offers easy beam alignment, but please be careful about the following points.

- 1) When reflecting objects such as window glass or shiny floor are placed near the units, beams could be reflected by the objects and could not detect intrusion.
- 2) For 2-stacked protection, do not install the two transmitters on the same side. Ensure that the upper and lower units consist of transmitter and receiver to avoid cross talk. Use different frequency (H and L) for each two units.

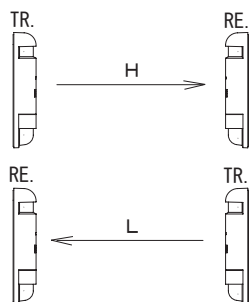

● Frequency is selectable for H and L which are corresponding to 1ch and 3ch of PB-IN-HF series or PB-TE series.

● For 2-stacked protection, in-line protection by two or more units is not available.

Expansion of beam

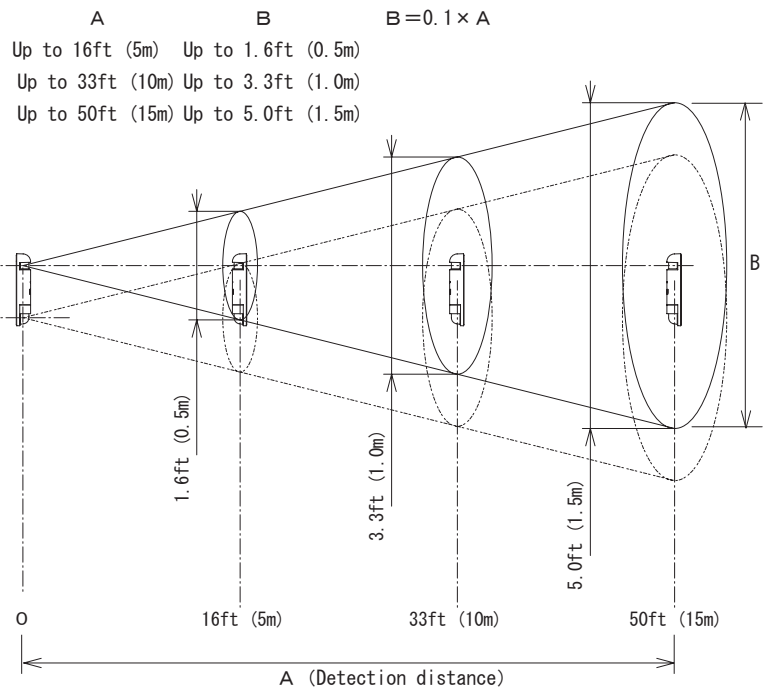

4 WIRING

Terminal arrangement

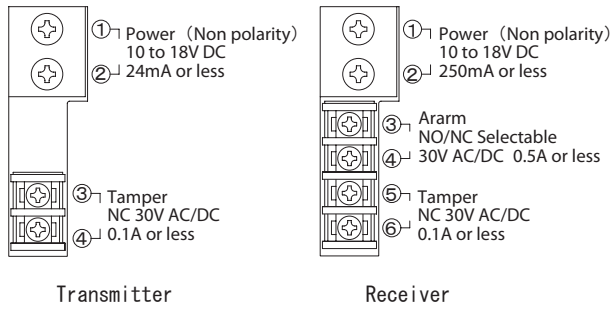

Standard connection

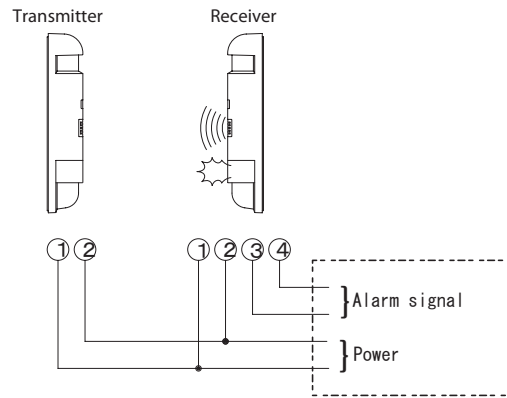

Wiring distance between sensor and controller

Wire size	Model	
	Voltage	PBS-15T DC12V
AWG22 (Dia. 0.65mm)		Up to 135ft (40m)
AWG20 (Dia. 0.8mm)		Up to 230ft (70m)
AWG19 (Dia. 0.9mm)		Up to 295ft (90m)
AWG18 (Dia. 1.0mm)		Up to 360ft (110m)
AWG17 (Dia. 1.1mm)		Up to 430ft (130m)

Multiple connection

In-line protection

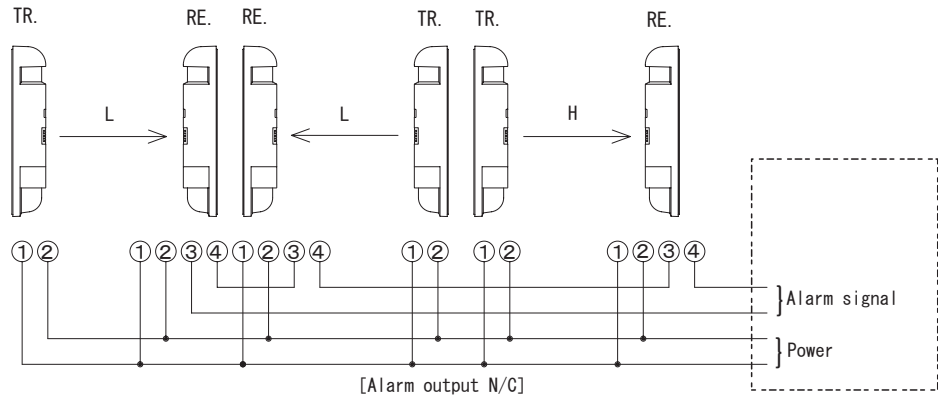

2-stacked protection

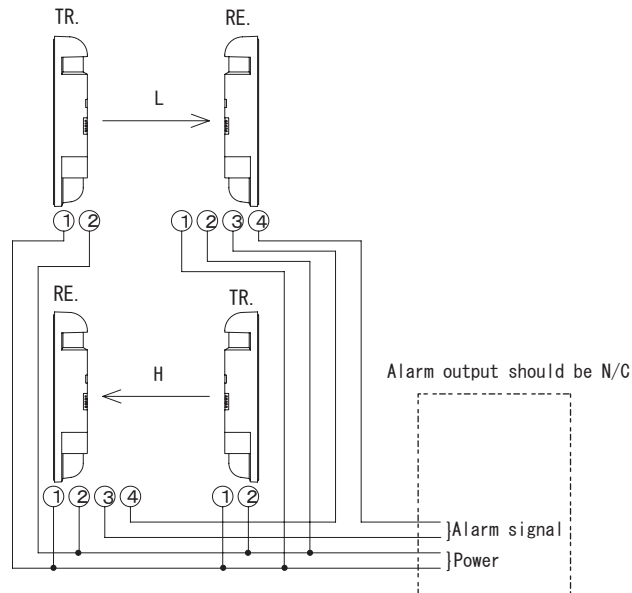

5 INSTALLATION

Wall Mount

- 1) Remove the cover from the unit and slide the mounting plate to detach it.
Place the mounting plate against the wall as a template for drilling and
- 2) mark the screw holes.
(Allow space 50mm above the plate and 10mm below the plate.
This will provide easy detachment of the cover after installation.)
Pre-drill the wall.

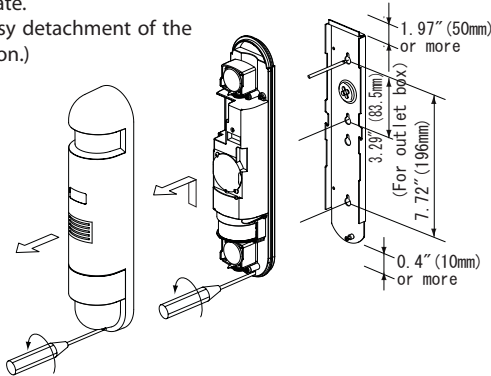

- 3) Pull the wire through the grommet and fix the mounting plate.
* The grommet is compatible with a wire of $\phi 0.12''$ ($\phi 3\text{mm}$) to $\phi 0.24''$ ($\phi 6\text{mm}$) outer dia.
When a wire of more than $\phi 0.24''$ ($\phi 6\text{mm}$) outer dia. is used, cut off the dotted line portion on the figure by pliers or the like.

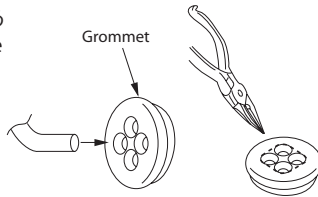

Then make corking to prevent insects from entering into the unit.

- 5) Pull the wire through the sensor body (back to front) and fix the sensor body to the mounting plate with a fixing screw.

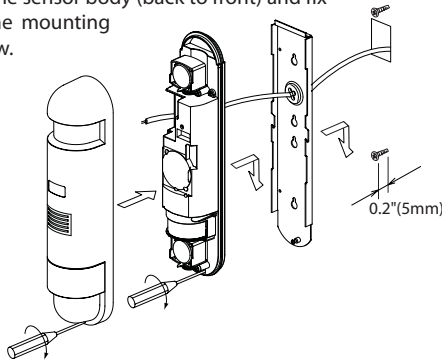

(Exposed wiring)

When the wiring is exposed, break knockouts on the rear of the unit and pull through the wire.
Make corking to prevent insects from entering into the unit.
Break knockout on the cover as small as necessary.

- 6) After connecting the wires to terminals, supply power, adjust beam alignment and check operation.

Then attach the cover and fix the unit.

Fence protection

For fence protection, use a pole and install the unit to the pole. (Please refer to "Pole mount".)

Pole mount

Note: Use a 1.66" to 1.75" (38 to 45mm) outside diameter pole.

- 1) Fix the pole mounting plate to the pole with U brackets and tapping screws.
- 2) Detach the cover from the sensor body and remove the mounting plate from it.
- 3) Fix the mounting plate of the sensor body to the pole mounting plate with tapping screws.
- 4) Repeat the same procedure of "Wall mount 4) to 6)".

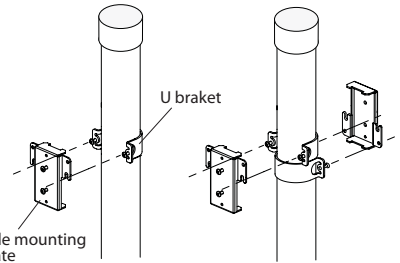

* Pole mounting back to back

- 1) Fix the first pole mounting plate to the pole.
- 2) Then install the second pole mounting plate to the pole so that those two pole mounting plates face opposite directions.
- 3) Repeat the same procedure of "Wall mount 4) to 6)".

6 BEAM ALIGNMENT

- 1) Supply power with cover off.
- 2) Set the angle of the transmitter lens and receiver lens so that they face each other. If the attenuation LED lights, it means that the beam is attenuated below proper range. In this case, readjust the angle of the lenses until both attenuation LED and alarm LED turn off.
- 3) Fine-tune the transmitter lens first.
 - (E) Cover the lower lens of the transmitter with cardboard etc. and turn the upper lens right and left and confirm the beam range.
 - (月) Set the angle of the lens to the middle of the beam range.
 - (火) Cover the upper lens of the transmitter with cardboard etc. and turn the lower lens right and left and confirm the beam range.
 - (水) Set the angle of the lens to the middle of the beam range.

Fine-tune the receiver lens second.

Repeat the same procedure as above for fine-tuning the receiver lens.

After beam alignment, walk across the beam and confirm that the alarm LED lights. If the alarm LED does not light, beam reflection against wall or window glasses in close proximity could cause lost alarm (no alarm).

In this case, readjust the angle of the unit as following procedures.

- (E) Cover the lower lens of the transmitter and turn the upper lens in a direction away from reflecting objects such as wall or window glasses.
Set the angle of the upper lens to the position just before the attenuation LED (Receiver) lights.

- (月) Repeat the same procedure as (E) for the lower lens of the transmitter.

- (火) Cover the lower lens of the receiver and turn the upper lens in a direction away from

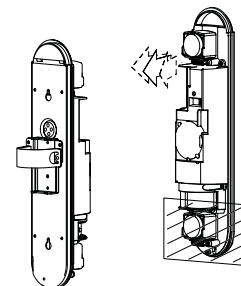

7 FUNCTION DESCRIPTION

(1) Functional settings of the dip switches (Receiver)

No.1 Siren/Day

ON <input checked="" type="checkbox"/>	Sound a siren during daytime (Factory setting)
OFF <input type="checkbox"/>	Not sound a siren during daytime

No.2 Siren/Night

ON <input checked="" type="checkbox"/>	Sound a siren during nighttime (Factory setting)
OFF <input type="checkbox"/>	Not sound a siren during nighttime

No.3 Flash light

ON <input checked="" type="checkbox"/>	Flash lights blink during detection (1min. delay time) (Factory setting)
OFF <input type="checkbox"/>	Flash lights are disabled.

No.4 Alarm output (NO/NC selectable)

ON <input checked="" type="checkbox"/>	N/C (Factory setting)	Normally closed: When detecting: Opened (When power down: Opened)
OFF <input type="checkbox"/>	N/O	Normally opened: When detecting: Closed (When power down: Opened)

No.5 Frequency selectable (Receiver)

ON <input checked="" type="checkbox"/>	H	Frequency H is selected. (Select the same frequency as the transmitter)
OFF <input type="checkbox"/>	L (Factory setting)	Frequency L is selected. (Select the same frequency as the transmitter)

No.6 Siren timer

ON <input checked="" type="checkbox"/>	20 sec.	Sound a siren for 20 sec. (One-shot operation)
OFF <input type="checkbox"/>	5 sec. (Factory setting)	Sound a siren for 5 sec. (One-shot operation)

(2) Frequency selectable switch (Transmitter)

ON <input checked="" type="checkbox"/>	H	Frequency H is selected (Select the same frequency as the receiver)
OFF <input type="checkbox"/>	L (Factory setting)	Frequency L is selected (Select the same frequency as the receiver)

(3) Functional setting of the receiver

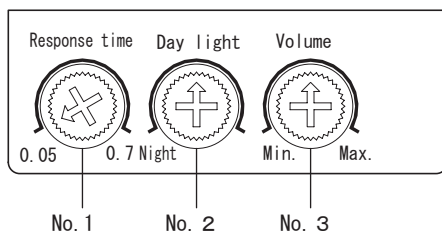

No.1 Response time

Response time is adjustable. Select 0.05 sec. and people running at full speed can be detected. When the unit is installed in a place where people cannot run at full speed due to fence or wall, set the response time a little longer and false alarms caused by falling leaves etc. can be reduced.

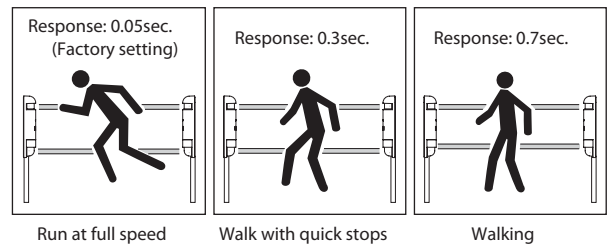

No.2 Day light

The unit decides it is night when the surrounding environment is darker than the set illuminance. (Adjustable range: Between approx. 10 lx and 1000 lx) Factory setting: Middle (Approx. 500 lx)

No.3 Volume

Siren volume is adjustable between Min. (silence) and Max. Factory setting: Middle

8 TROUBLESHOOTING

Solve possible problems according to the following table .
If normal operations can not be restored by these corrective actions, contact either the dealer from whom you bought the unit or TAKEX.

Symptom	Possible cause	Remedy
Transmitter LED doesn't light	1) No power supply. 2) Bad wiring connections or broken wire, short.	1) Supply power. 2) Check and correct wiring.
Receiver alarm LED does not light when the beam is blocked.	1) Disruption of power or inadequate wiring. 2) Reflected beam is coming into receiver. 3) Two beams are not blocked simultaneously. 4) Beam interruption time is shorter than response time.	1) Correct power supply. 2) Remove the reflecting object or readjust the beam angle. 3) Ensure all beams are blocked at same time. 4) Adjust response time.
Receiver alarm LED stays lit (Flash light continues to light.)	1) Poor alignment. 2) Obstruction between Transmitter and Receiver. 3) Optics of units are dirty. 4) Frequency channel setting on transmitter does not match with that on receiver.	1) Check and adjust beam alignment. 2) Remove any possible obstacles. 3) Clean the optics with a soft cloth. 4) Readjust to the same channel.
Intermittent alarm	1) Bad wiring connection. 2) Fluctuation of supply voltage. 3) Obstructing object between transmitter and receiver 4) Transient spikes on supply cables. 5) Loose installation of transmitter and receiver. 6) Optics of units are dirty. 7) Poor alignment. 8) Animals pass through the two beams.	1) Check again. 2) Stabilize supply voltage. 3) Remove the obstruction. 4) Re-locate. 5) Tight on. 6) Clean the optics with a soft cloth. 7) Check and adjust again. 8) Set the response time longer. (Not available at a place where intruder can run at full speed.)
No siren when the beam is broken.	1) Min. on the sound volume is selected. 2) Siren sound is disabled by day light function.	1) Adjust volume. 2) No problem.

9 SPECIFICATIONS

Model	PBS-15T
Detection distance	Outdoor 50ft (15m) or less (Indoor 100ft (30m) or less)
Max. arrival distance	Outdoor Tenfold 500ft (150m) Indoor Fivefold 500ft (150m)
Infrared beam	Double modulation pulsed beam by LED
Detection system	Simultaneous breaking of 2 beams
Response time	0.05sec. to 0.7sec. variable (Standard: 0.05sec.)
Supply voltage	10V to 18V DC (Non-polarity)
Current consumption	Transmitter: 24mA / Receiver: 250mA
Day light	Recognize it is night when surrounding environment is darker than the set illuminance.
Alarm output	Dry contact relay output NO/NC selectable Contact: 30V AC/DC 0.5A (Resistive load) Contact action: Interruption time (Min. 2sec.)
Tamper output	Dry contact output NC Contact capacity: 30V AC/DC 0.1A
Flash light output	Color: Red Interruption time + Delay time (1 min.)
Siren output	Volume: Silence to approx. 90dB/1m Variable with a volume Siren timer: 5sec./20sec. selectable (One-shot operation)
Alarm LED	Red LED (Receiver) Lights when an alarm is initiated.
Attenuation LED	Red LED (Receiver) Lights when beam is attenuated.
Transmitting LED	Green LED (Transmitter) Lights when beam is transmitted.
Functions	Frequency selectable for L or H, AGC circuit, Frost proof cover
Ambient temperature range	-13° F to +140° F (-25°C to +60°C)
Beam alignment adjustment	Horizontal: ±90°
Installation	Indoor/Outdoor
Wiring	Terminals
Weight	Transmitter: 560g Receiver: 620g
Appearance	PC resin (wine red)
Accessories	Tapping screw $\phi 4 \times 20$: 4 pcs Pole attachment: 2 sets

10 EXTERNAL DIMENSIONS

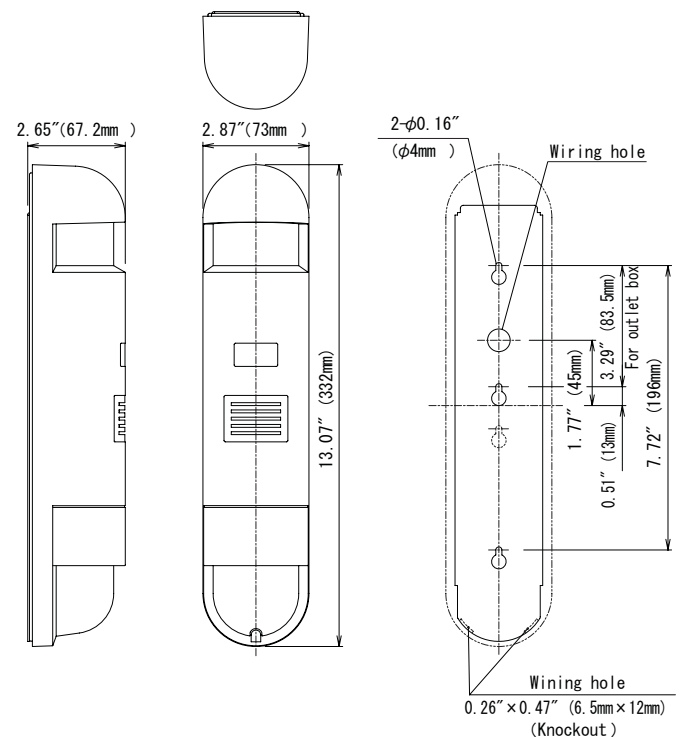

Limited Warranty :

TAKEX products are warranted to be free from defects in material and workmanship for 12 months from original date of shipment. Our warranty does not cover damage or failure caused by Acts of God, abuse, misuse, abnormal usage, faulty installation, improper maintenance or any repairs other than those provided by TAKEX. All implied warranties with respect to TAKEX, including implied warranties for merchantability and implied warranties for fitness, are limited in duration to 12 months from original date of shipment. During the Warranty Period, TAKEX will repair or replace, at its sole option, free of charge, any defective parts returned prepaid. Please provide the model number of the products, original date of shipment and nature of difficulty being experienced. There will be charges rendered for product repairs made after our Warranty period has expired.



In Japan
Takenaka Engineering Co., Ltd.
83-1, Gojo-sotokan, Higashino,
Yamashina-ku, Kyoto 607-8156, Japan
Tel : 81-75-501-6651
Fax : 81-75-593-3816
<http://www.takex-eng.co.jp/>

In the U.S.
Takex America Inc.
230E, Caribbean Drive
Sunnyvale, CA 94086, U.S.A.
Tel : 408-747-0100
Fax : 408-734-1100
<http://www.takex.com>

In Australia
Takex America Inc.
Unit 16/35 Garden Road, Clayton,
3168 Victoria, Australia
Tel : 03-9546-0533
Fax : 03-9547-9450

In the U.K.
Takex Europe Ltd.
Takex House, Aviary Court, Wade Road,
Basingstoke, Hampshire. RG24 8PE, U.K.
Tel : (+44) 01256-475555
Fax : (+44) 01256-466268
<http://www.takexeurope.com>